

Designing for a Medical Application: Choosing the Right Power Partner

Created by

Advanced Energy Industries, Inc.

Shane Callanan, director of Innovation Engineering considers the selection process required for choosing the most suitable supplier for a medical power supply.

Abstract

This paper will discuss how you can ensure that you source both the correct power supply and also the right company for your medical application requirements. It also discusses the additional risk analysis requirements for EN60601-1-1:2005, and emphasizes the importance of relationship building with your power supply vendor to ensure adherence to same.

Table of Contents

Introduction	2
How to Identify a Potential Power Supply Vendor for Your Needs	2
Establishing That the Power Supply and the Company are the Right Choice for your Design	2
Choosing the Right Partner	3
How to Ensure You Ask the Right Questions of Your Partner	5
EN60601 3 rd Edition Risk Analysis Compliance	6
Summary	7

Introduction

Power supplies are a critical part of any system, and, as such, great care must be taken in choosing the right power supply. In particular for medical power supplies that must comply with EN60601, additional requirements that must also be considered are the risk analysis and risk management issues. EN60601-1-1:2005, more commonly referred to as EN60601, 3rd edition, requires not only the additional risk management aspect but also the competency of the individuals to carry out this risk analysis. In light of this requirement alone it is imperative that you choose not only the right power supply but also the right company to ensure that you will be supported throughout the lifetime of the product.

How to Identify a Potential Power Supply Vendor for Your Needs

Once you have a general concept of your system you will begin to have an understanding of the electrical and mechanical requirements. From here, your specifications can then be categorized into three sections basic, critical, or special requirements. Basic specifications will cover some key items such as input voltage range, output voltage and current requirements, and the form factor. Critical specifications will cover your isolation requirements, safety approvals, EMI performance, and on-board protection and so on. Finally, special requirements will involve any particular requirements for your given application. Once these are established and your budget is defined you can now engage with a vendor.

Establishing That the Power Supply and the Company are the Right Choice for your Design

In choosing a vendor, you should not limit your search to identifying a company that can just supply you with a once-off solution. You should instead be looking to identify a company who can support you on all aspects of the project for the lifetime of the project. After all, you will not be looking for the company to just sell you a solution. You will need support in many forms. Customer support, engineering support, and field support issues are just but a few that will be required over the lifetime of the project. There will also be support documentation required for various agencies as your finished product goes through with approvals agencies. Thus, in many ways you should not just be looking for a vendor, but focus your efforts on finding the right partner.

Choosing the Right Partner

Despite the level of detail that you put into before integrating a power supply into your system, there will inevitably be some characteristic of the design that will need to be looked at in more detail. When this arises it is paramount that all relevant parties get involved as soon as possible. This may range from some obscure (and maybe irrelevant) event right up to the unit not being able to accommodate the applications requirements at some particular operating condition. This is where choosing the right partner will really pay dividends.

In one such case, a customer of Advanced Energy was using the Xgen series with very high capacitive loading. Because of this large capacitive loading, we saw excessive energy being forced back into our unit on shut down. On-board the Xgen we have negative current limit, and this was being engaged. Consequently, we observed high voltage peaks on shut down, which was being interpreted by our unit as an over voltage event. A further protective circuit on-board was thus engaging and our design was latching itself in an off state. If the user tried to power cycle within a 2-minute period, the latch circuit remained charged, and the unit would not turn on. This was being reported as an intermittent failure at the customer’s location. After early discussions with our customer, we were able to offer a number of solutions, both internal and external to the Xgen series. After reviewing all solutions, an agreement was reached to offer the customer a modification of our standard product on which we moved the trigger level of the over voltage protection. The key point to resolving this issue in a timely fashion was based on the relationships between our two companies. Engineering staff from both sides had a clear understanding of the issue, it was communicated clearly, and once a resolution was identified and agreed by all it was implemented in the product.

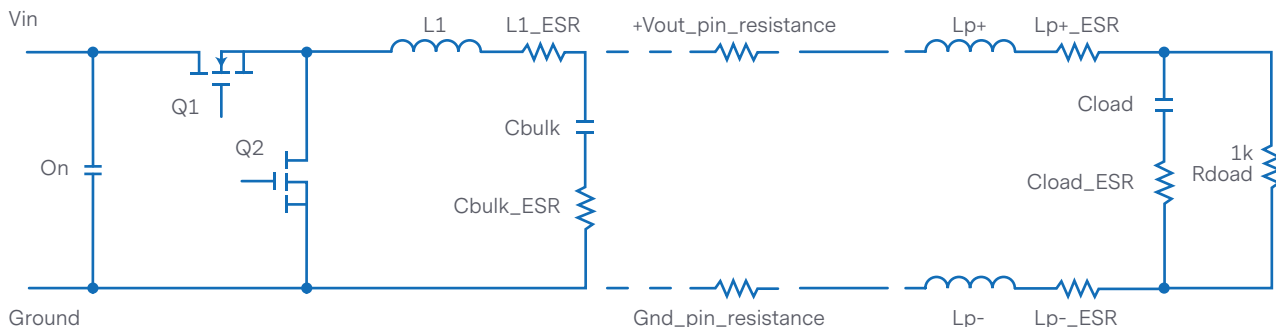

DESIGNING FOR A MEDICAL APPLICATION: CHOOSING THE RIGHT POWER PARTNER

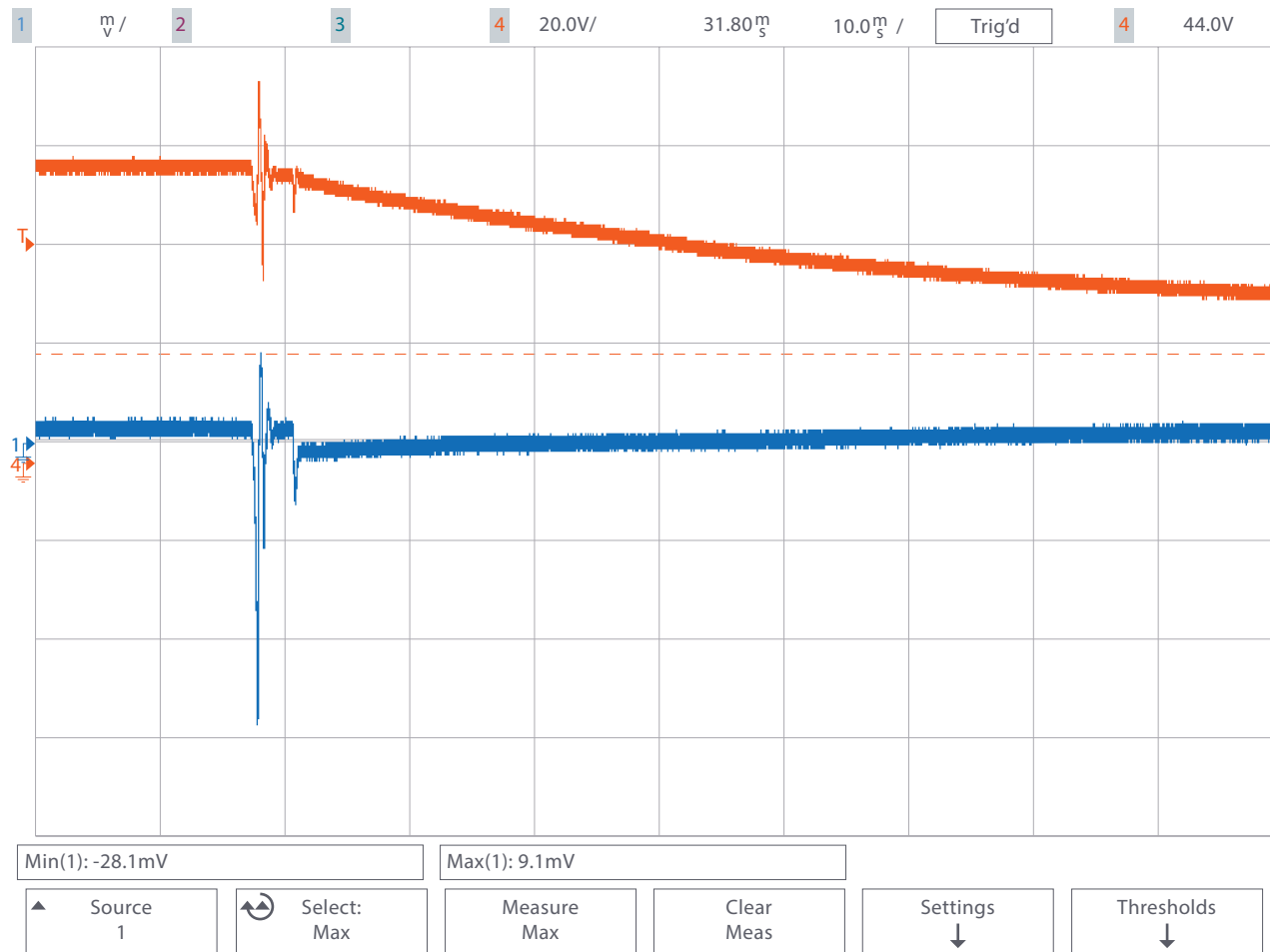

Channel1 (Red) above shows the resultant output voltage spike occurring when the negative current limit is reached, and the output stage goes high impedance. Energy from the load is no longer being dissipated by the power supply and the voltage rises.

How to Ensure You Ask the Right Questions of Your Partner

A full divulgence of your design to the power supply company is not required, and the reality is, that your company will want to protect its intellectual property. This may curtail the amount of information that can be divulged to outside parties. However, the more information that can be supplied to the technical team the better equipped they will be to assist you. This is again where the relationship should be viewed as partnership. Non Disclosure Agreements should be sufficient to protect the concerns of all parties.

What would be required is an understanding of the type of load. Is it primarily a capacitive, resistive, or an inductive load? Are you driving a motor, or will there be large transients on the output? Of course a customized power supply will be designed to accommodate all of the specified requirements, but in some situations the standard off-the-shelf design may not meet every requirement of a particular application. This may require an external circuit or component to enable reliable use in your system. When reviewing the datasheet, you should dig a little bit deeper to understand if the values presented are typical, minimum, or maximum values. You should also look at how things like PFC, efficiency, ripple, and noise will perform for your particular line and load requirements. Often the banner headlines do not portray the full picture.

Another key feature to be addressed is compliance and certification to EN60601-1-1:2005

EN60601 3rd Edition Risk Analysis Compliance

As a medical device manufacturer, "risk management" is a term you will be familiar with. The 3rd Edition of IEC 60601-1 now requires you to demonstrate that you have a documented risk management system in place to verify that your device is safe. Manufacturers are not necessarily required to have a risk management audit and UL does offer the option of a desktop assessment to receive a UL mark to 3rd edition. Field experience can also be used, as long it is not the sole basis of establishing compliance.

For 3rd edition certification, the manufacturer's risk management process will be assessed. The risk management file is key and will need to capture the outputs of your risk management process. The guidelines for these call for all foreseeable misuse, and should take into consideration some modes of operation that would be outside of the specified operating limits. You will need to outline the work carried out and detail how you reached these conclusions. It should be carried out and be in keeping with ISO14971, which provides a framework to develop a risk management. The requirements of this standard apply to all stages of the product's life cycle, from concept through to volume production.

The competency of those involved in carrying out this analysis is key to ensuring the smooth transition to 3rd edition compliance and your relationship with your vendor.

Summary

In summary when choosing a power supply vendor, look for a long-term solution. You will need to satisfy yourself that your partners can support you over the lifetime of your design.

- Ensure the product meets your requirements and read the small print.
- Establish all key contacts with which you can engage with right from the get-go of your design.
- Engage with the technical teams as early as you can during your design phase.
- Consider future expansion of your base design. Is the solution scalable?
- Ensure the chosen partner has a technical structure that can support you over the lifetime of the project.
- Create and foster long term relationships.



For international contact information,
visit advancedenergy.com.

sales.support@aei.com
+1.970.221.0108

ABOUT ADVANCED ENERGY

Advanced Energy (AE) has devoted more than three decades to perfecting power for its global customers. AE designs and manufactures highly engineered, precision power conversion, measurement and control solutions for mission-critical applications and processes.

AE's power solutions enable customer innovation in complex semiconductor and industrial thin film plasma manufacturing processes, demanding high and low voltage applications, and temperature-critical thermal processes.

With deep applications know-how and responsive service and support across the globe, AE builds collaborative partnerships to meet rapid technological developments, propel growth for its customers and power the future of technology.

PRECISION | POWER | PERFORMANCE

Specifications are subject to change without notice. ©2018 Advanced Energy Industries, Inc. All rights reserved. Advanced Energy® and AE® are U.S. trademarks of Advanced Energy Industries, Inc.