



INTERFACE CARD PROFIBUS DPV1

FOR THYRO-P AND THYRO-P MC

July 2014

DE/EN - V3



CONTENTS

1. Safety notes	4
2. Safety requirements	9
3. Notes on these operating instructions	13
4. Contact	15
5. Introduction	16
6. Configuration	17
6.1 Setting the address	17
6.2 Start configuration	17
7. Operation	19
8. Cyclic data exchange	20
8.1 Setpoint values	21
8.2 Actual values	22
8.3 Functions	22
8.4 Modules	23
9. Acyclic data transmission (parameterization)	24
10. Diagnosis indications	25
11. Digital inputs	27
12. Local operation of the motorpoti setpoint	28
13. Setpoint values, actual values and parameters	31

LIST OF ILLUSTRATIONS AND TABLES

Fig. 5.1	PROFIBUS DPV1 insert card	16
Fig. 11.2	Example of input connections	27
Fig. 12.1	Relative change of the Motorpoti setpoint over time	28
Fig. 12.2	Local operation of the Motorpoti setpoint	29
Fig. 12.3	State digram	30
Tab. 7.1	Status of diagnosis LED	19
Tab. 8.1	Implication of the first byte of the module configuration	20
Tab. 8.2	Functions	22
Tab. 10.1	Set up of the diagnosis diagram	25
Tab. 10.2	Set up of word's actual status	26
Tab. 11.1	Connection allocation X21	27
Tab. 13.1	Setpoint values (Slot 0)	31
Tab. 13.2	Functions (Slot 0)	31
Tab. 13.3	Actual values (Slot 0)	32
Tab. 13.4	Operating mode (Slot 1)	33
Tab. 13.5	Durations (Slot 2)	33
Tab. 13.6	Control (Slot 3)	34
Tab. 13.7	Limit (Slot 4)	34
Tab. 13.8	Control characteristic (Slot 5)	35
Tab. 13.9	Temperature (Slot 6)	35
Tab. 13.10	Analogue outputs (Slot 7)	36
Tab. 13.11	Hardware parameters (Slot 8)	37
Tab. 13.12	Monitoring (Slot 9)	38
Tab. 13.13	LEDs and Relays (Slot 10)	39
Tab. 13.14	Other (Slot 11)	40
Tab. 13.15	Functions (Slot 12)	40

1. SAFETY NOTES

The safety notes and the operating instructions are to be read carefully before installing and commissioning.

1.1 OBLIGATORY INSTRUCTION

These safety notes and the operating instructions shall carefully be read by the persons deployed for work using and employing the PROFIBUS DPV1 interface card prior to assembly, installation and the initial start-up of the PROFIBUS DPV1 interface card. These operating instructions are part of the PROFIBUS DPV1 interface card.

The operator of the device is committed to provide these operating instructions without limitation to all persons, who transport the device, start it up, maintain it, or perform other work tasks to it.

In accordance with the Product Liability Act the manufacturer of this product is obligated to inform about and warn against

- other than the intended use of a product
- the residual hazards of a product as well as
- incorrect usages and their consequences

The following information is intended for this purpose. This information should warn the product user and protect him and his appliances.

1.2 APPROPRIATE USAGE

- The PROFIBUS DPV1 interface card is an interface component which may only be operated in connection with the Thyro-P.
- As a component the PROFIBUS DPV1 interface card is not functional on its own and must be project planned for its appropriate usage in order to minimize the residual hazards of the product.
- The PROFIBUS DPV1 interface card may only be used for the purpose for which it was intended, as persons may otherwise be exposed to dangers (e.g. electric shock, burns) and systems also (e. g. overload).
- It is not permitted to make any unauthorized modifications to the device or to use any spare parts or replacement parts not approved by Advanced Energy, or to use the device for any other purpose.
- The warranty obligations of the manufacturer are only applicable if these operating instructions are observed and complied with.
- The PROFIBUS DPV1 interface card connects a Thyro-P with a master.
- The devices supplied have been produced in accordance with the ISO 9001 quality standard.

- Multiple plug-in cards can be used on one assembly.
- The power supply for the plug-in card comes through the Thyro-P.

1.3 RESIDUAL HAZARDS OF THE PRODUCT

Even with intended use it is possible, in the case of an error, that the currents, voltages or power in the load circuit are no longer affected by the PROFIBUS DPV1 interface card.

If the power components are destroyed, for example, the following cases are possible: current interruption, continual flow of energy. If such a case occurs, then the occurring load voltages and currents result from the physical sizes of the overall circuit. Throughout the project planning of the system it must be ensured, that no uncontrolled large currents, voltages or power can occur.

1.4 INCORRECT OPERATION AND THEIR CONSEQUENCES

In the case of incorrect operations, higher power, voltages or currents than intended can reach the PROFIBUS DPV1 interface card, the thyristor power controller or the load. This can cause damage to the PROFIBUS DPV1 interface card, the thyristor power controller or the load.

In particular, factory-set parameters may not be altered in such a way that the Thyro-P or the PROFIBUS DPV1 interface card are overloaded.

1.5 SCOPE OF SUPPLY

The supply consists of the following parts:

- Interface card PROFIBUS DPV1
- Operating instructions

1.6 STORAGE

The devices may be stored originally OEM packaged in rooms, which are dry and ventilated.

- permissible ambient temperature: -25°C to +55°C
- permissible relative air humidity: max. 85%

For longer storage durations, the devices should be contained in airtight plastic skins with the addition of commercially available drying agents.

1.7 ASSEMBLY

- If stored in cold environments it must be ensured that the device is absolutely dry before commissioning. Therefore allow at least 2 hours acclimatization time before commissioning.
- Ensure sufficient ventilation and deaeration of the cabinet if mounted in a cabinet.
- Observe minimum spacing.
- Ensure that the device cannot be heated up by heat sources below it. (see Technical data).
- Ground the device in accordance with the local regulations.
- Connect the device in accordance with the connection diagrams.

1.8 CONNECTION

Before connection, the indicated voltage on the type plate is to be compared with the mains voltage to make sure they match.

The electrical connection is made at the points labelled on the Thyro-P.

1.9 OPERATION

The PROFIBUS DPV1 interface card may only be started when there is absolutely no danger to persons or system.

- Protect the device against dust and damp.
- Ensure that the ventilation opening is not blocked.

1.10 MAINTENANCE, SERVICE, FAULTS

The symbols used in the following are explained in the chapter on safety requirements.

In order to avoid damage to personnel or property the user must note the following points before all work:

**CAUTION**

In the case of smoke or smell development, as well as in the case of fire, the device must be disconnected from all external voltage sources.

**CAUTION**

For maintenance and repair works the device must be disconnected from all external voltage sources and safeguarded against it being switched on again. After switching off wait at least two minutes for the snubber capacitors to discharge. The absence of voltage is to be ascertained using appropriate measurement instruments. The device is to be grounded and short-circuited. Adjacent components under voltage are to be covered or separated off. These activities may only be carried out by an electrically qualified person. The local electrotechnical regulations are to be adhered to.

**CAUTION**

The thyristor power controller contains voltages which are hazardous. Repairs are strictly only to be carried out by qualified and trained maintenance personnel.

**CAUTION**

Hazard of electric shocks. Even after the separation from the mains, capacitors can still contain dangerously high levels of energy.

**CAUTION**

Hazard of electric shocks. Even with a non-activated thyristor controller the load circuit is not separated from the mains by the thyristor controller.

**ATTENTION**

Different power components are screwed in place with exact torques according to their function. For safety reasons repairs to power components are to be carried out by Advanced Energy.

1.11 DECOMMISSIONING AND REMOVAL

If shutting down and dis-assembling the device for the reason of venue change or for disposal purposes the following safety rules must be complied with prior to the beginning of all work performed:



ATTENTION MAINS VOLTAGE!

Safety rules for work performed to electrical facilities:

1. Disconnect the device from the power supply (establish a voltage free status)
2. Secure against re-activation
3. Verify by measurement that there is no voltage present
4. Ground and short-circuit equipment
5. Cover or separate adjacent parts which are under voltage

For dis-assembly, perform the following steps:

1. Separate the device from the 230VAC, respectively 110VAC, power supply.
2. Separate all other connections.

Electrical connections are thus dis-assembled and now, the device can be removed by dis-assembly from the overhead rail.

2. SAFETY REQUIREMENTS

2.1 IMPORTANT INSTRUCTIONS AND EXPLANATIONS

For the protection of personnel and the maintenance of good working order, usage and repairs must be in line with the guidelines, and the safety requirements listed must be adhered to. The personnel who set up / disassemble the devices, start them up, operate them, maintain them, must know and adhere to these safety requirements. All works may only be carried out by specialist personnel trained for the purpose and equipped with faultless tools, appliances, means of testing and materials required and intended for that purpose. In these operating instructions, there are important warnings before dangerous actions. These warnings are divided into the following classes of hazards:



DANGER

Hazards that can lead to serious injuries or fatal injuries.



WARNING

Hazards that can lead to serious injuries or considerable damage to property.



CAUTION

Hazards that can lead to injuries and damage to property.



CAUTION

Hazards that can lead to minor damage to property.

The warnings can also be supplemented with a special danger symbol (e.g. „Electric current“ or „Hot device“) , e.g.



in case of risk of electric current or



in case of risk of burns

In addition to the warnings, there is also a general note for useful information.

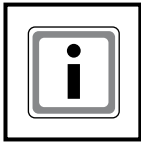

NOTE

Content of note

2.2 GENERAL DANGER INFORMATION



DANGER

Not adhering to the safety requirements in the operating instructions of the power controllers being used can lead to danger of injury / danger of damaging the device or system.

> Adhere to all safety requirements in the chapter “Safety” of the operating instructions of the power controllers being used.



DANGER

ELECTRIC CURRENT

Risk of injury from current carrying parts/danger of damaging the plug-in card. Never operate the device without covering.

Make adjustments and connections disconnected from the power supply.

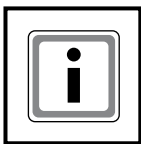

NOTE

Communication error

In order to avoid communication errors the following point has to be taken into account:

Use shielded cables.

2.3 QUALIFIED PERSONNEL

Only qualified personnel who are familiar with the pertinent safety and installation regulations may perform the following with the the PROFIBUS DPV1 interface card:

- transport
- installation
- connection
- commissioning
- maintenance
- testing
- operation

These operating instructions must be read carefully by all persons working with or on the device prior to installation and initial start-up.

2.4 REQUIREMENTS TO THE OPERATOR

The person responsible for the system must ensure that

- Safety notes and operating instructions are available and adhered to.
- Operating conditions and technical data are heeded.
- Protective devices are used.
- Maintenance personnel are informed immediately or the PROFIBUS DPV1 interface card or the Thyro-P, respectively, is taken out of action immediately if abnormal voltages or noises, higher temperatures, vibrations or similar occur, in order to identify the cause.
- The accident prevention regulations valid in the respective country of use and the general safety regulations are observed.
- All safety devices (covers, warning signs etc.) are present, in perfect condition and are used correctly.
- The national and regional safety regulations are observed.
- The personnel have access to the operating instructions and safety regulations at all times.

2.5 INTENDED USE



CAUTION

The PROFIBUS DPV11 interface card in connection with the Thyro-P may only be used for the purpose for which it was intended, as persons may otherwise be exposed to dangers (e.g. electric shock, burns) and systems also (e. g. overload).

It is not permitted to make any unauthorised modifications to the PROFIBUS DPV1 interface card or to use any spare parts or replacement parts not approved by Advanced Energy, or to use the device for any other purpose.

These operating instructions contain all the information required by skilled personnel using the device. Additional information and notes for non-qualified persons and for the use of the device outside of industrial assemblies are not contained in these operating instructions.

The warranty obligations of the manufacturer are only applicable if these operating instructions are observed and complied with.

2.6 LIABILITY

No liability is burdened for non-intended by the manufacturer use of the PROFIBUS DPV1 interface card. The operator or user, respectively, shall burden the responsibility for possibly necessary measures for the prevention of people and asset damage. In case of complaints, please contact us immediately and include the following information:

- type designation
- fabrication number /serial number
- complaint description
- duration in operations
- ambient conditions of the device
- mode of operation

3. NOTES ON THESE OPERATING INSTRUCTIONS

3.1 VALIDITY

These operating instructions correspond with the technical status of the PROFIBUS DPV1 interface card at the time of issue. The content is not the subject of the contract, but rather serves to provide information. We reserve the right to make amendments to the details in these operating instructions, in particular to technical data, operation, measurements and weights. Advanced Energy reserves the right to make content amendments and technical alterations to the details in these operating instructions unannounced. Advanced Energy cannot be held responsible for any inaccuracies or incorrect details in these operating instructions as there is no obligation to make ongoing updates to these operating instructions.

These operating instructions serve only as an addition to be used in conjunction with the operating instructions of the Advanced Energy Thyro-P power controllers in the versions of the types indicated on the covering page. The safety instructions contained therein are to be observed in particular.

3.2 HANDLING

These operating instructions for the PROFIBUS DPV1 interface card are structured in a manner so that according expert personnel may perform all work necessary for commissioning, maintenance, and repair.

If threats to personnel and material cannot be ruled out for certain work, such tasks are marked with a pictogram, from which the according content may be extracted from the before mentioned chapter „Safety requirements“.

3.3 TYPE DESIGNATION

Interface card PROFIBUS DPV1 order no. 2000 000 393

3.4 LOSS OF WARRANTY

Our supplies and services are subject to the general conditions of supply for products of the electrical industry, as well as our general sales conditions. Claims in connection with supplied goods must be submitted within eight days upon receipt, along with the packing slip. Claims made later cannot receive consideration.

Advanced Energy will rescind all possible obligations such as warranty agreements, service contracts, etc. entered into by Advanced Energy or its distributors without prior notice if maintenance and repair work is carried out using anything other than original Advanced Energy spare parts or spare parts purchased from Advanced Energy.

3.5 COPYRIGHT

No part of these operating instructions may be transmitted, reproduced and/or copied by any electronic or mechanical means without the express prior written permission of Advanced Energy.

© Copyright Advanced Energy Industries GmbH 2014.

All rights reserved.

3.6 FURTHER INFORMATION ON COPYRIGHT

Thyro-™, Thyro-P™ are registered trademarks of Advanced Energy Industries GmbH.

All other company and product names are (registered) trademarks of the respective owners.

4. CONTACT

4.1 TECHNICAL QUERIES

Do you have any technical queries regarding the subjects dealt with in these operating instructions?

If so, please get in touch with our team for power controllers:

Phone +49 (0) 2902 763-520

4.2 COMMERCIAL QUERIES

Do you have any commercial queries on power controllers?

If so, please get in touch with our team for power controllers.

Phone +49 (0) 2902 763-558

4.3 SERVICE

Advanced Energy Industries GmbH

Branch Office Warstein-Belecke

Emil-Siepmann-Straße 32

D-59581 Warstein

Phone +49 (0) 2902 763-0

4.4 INTERNET

Further information on our company or our products can be found on the Internet under:

<http://www.advanced-energy.com>

5. INTRODUCTION

This communication card complements the Thyro-P (Thyristor power controller) with the communication interface PROFIBUS DPV1. The interface card allows the Thyro-P to be integrated into complex installations via the field bus. Additionally, the card has 3 electrically isolated inputs (see Section 6) which can be accessed via terminal X21.

Delivery includes:

- a PROFIBUS DPV1 interface card
- a screen for installation into the Thyro-P
- a CD with the GSD data necessary for projection
- these instructions.

The PROFIBUS connection is lead through a 9-pole sub-D bushing (X20). It provides access to data lines A and B as well as an electrically isolated distribution voltage (5 V, 80 mA).

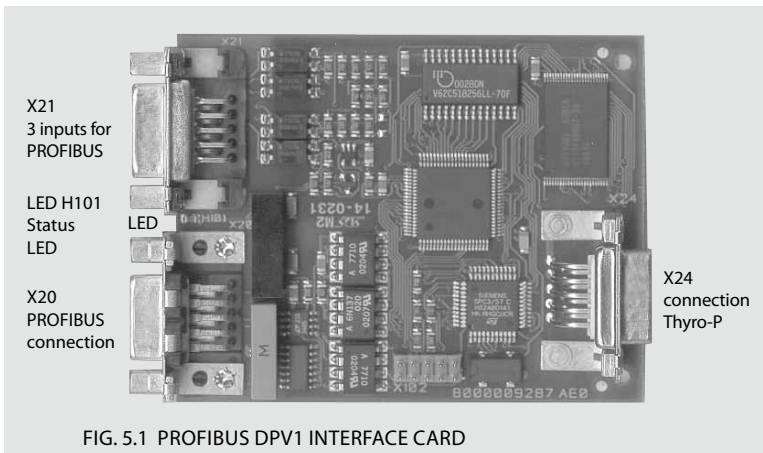

6. CONFIGURATION

6.1 SETTING THE ADDRESS

In order to communicate, the PROFIBUS DPV1 interface card needs an address. This same address is also used for communicating via LWL and RS232. This can be set with the LBA-2 and the Thyro-Tool Family.

Please note that in order to activate the new address the Thyro-P must be switched off after changing a controller address.

6.2 START CONFIGURATION

The following settings can be made via parameterization.

Valid output data:

Here the suppression of certain output data can be activated.

"Everything"	All telegrams are processed.
"Ignore Clear"	Ignores the "Master Clear" telegram and the output data with length 0.
"Only if bit is set"	New output data is only accepted if the bit "use output data" is set (see Section 4.3).

Motorpoti = Master:

Activates writing the "Master setpoint" onto the "Motorpoti setpoint" if the controller is in remote operation and the PROFIBUS is in the "DataExchange" state.

Setpoint error =:

Here the set point to be applied in the case of an error can be set.

"Setpoint Master error"	Application of the alternative setpoint
"Setpoint Master"	Do not adjust setpoint.

The following are considered errors:

- Watchdog response
- "Master Clear" telegram received
- Output telegram with length 0 received.

Actual values average:

Here the mean value of the actual values can be activated. In the Takt operating mode once per T_0 is measured, with VAR once per 0.2 s.

"5 values"	mean value taken above 5 values
"10 values"	mean value taken above 10 values
"20 values"	mean value taken above 20 values

Local values:

Here it can be determined which values can be set locally in "local operation".

"Only master setpoint"	Only the setpoints are preset locally.
"All values"	No value is preset by the master.

Status indications:

Every status indication (see Section 5) can be set to show up on the relevant diagnosis indication of each device.

7. OPERATION

After configuration of the interface card has been completed (Section 2) this can be built into the controller section of the Thyro-P. First the voltage in the control section must be switched off. Now the card can be inserted into the extension socket and the cover mounted.

Next, the interface card can be tested. The voltage supply of the control section must hereby be switched on. The status-LED displays the status of the card (see Table 7.1). The status-LED is situated between the connectors X20 and X21.

After switching on the controller section the LED should blink with a frequency of 1Hz. Then the bus line can be connected. After communication with the master the status LED is extinguished.

STATUS LED	BUS	IMPLICATION
On	–	Card defect
Blinks with 4 Hz	–	No communication with Thyro-P (SSC error)
Blinks with 1 Hz	off	No bus signal exists
Blinks with 1 Hz	active	Card defect
Off	off	No connection to Thyro-P
Off	active	Everything OK

TAB. 7.1 STATUS OF STATUS LED

8. CYCLIC DATA EXCHANGE

Via the cyclic data exchange the input and output data are continuously transmitted from slave to master and vice-versa.

The Thyro-P possesses a large amount of input and output data.

As all this data is not always required, it can be selected individually.

This prevents an unnecessary enlargement of the protocol.

The collation of the input and output data is carried out by adding modules. All manufacturers of master systems offer the corresponding configuration tools for this.

When adding modules, the parameterization telegram is enlarged each time by two bytes. Via these bytes the slave is instructed which input and output data to transmit. A rough allocation takes place via the first byte (see Table 8.1). The second byte contains the index of the parameters concerned (see Section 13).

VALUE	INPUT, OUTPUT DATA
0	Setpoint values integer
1	Setpoint values float
2	Actual values float
3	Actual values integer
4	Functions
16-27	Write integer in slot 1-12
32-43	Read integer from slot 1-12

TAB. 8.1 IMPLICATION OF THE FIRST BYTE OF THE MODULE CONFIGURATION



ATTENTION

Should the configuration data not correspond, this is due to the incorrect setting of these parameters, as the Thyro-P draws up its configuration from this data.

8.1 SETPOINT VALUES

The output control of the Thyro-P can take place via the following set-points:

“Setpoint master”

With this the load output can be controlled or adjusted.

“Setpoint master error”

If activated, this setpoint (see Section 6.2) is written onto the setpoint master if the PROFIBUS DPV1 should fail. In this case, it is important when configuring the master that the watchdog is activated. The „setpoint master error” is initialized with 0.

“Setpoint Motorpoti”

This too can control or adjust the load output. It should, however, only be applied in exceptions. Under no circumstances may it be applied if the “local operation of the Motorpoti” setpoint is to be applied (see Section 12).

Each of these setpoints can be indicated either as integer or float number, whereby only one number system at a time should be used.

Integer:

When applying the integer number system, 16383 corresponds to the setpoint 100%.

Float:

When applying the float number system the setpoint must be relayed in the controller’s unit, e.g. with I or I2 control the setpoint must be given in amperes.



NOTE

If the controller is in remote operation (only master setpoint is active) it is advisable to write the master setpoint onto the Motorpoti setpoint too, in order not to give a jump function to the controller in Thyro-P when switching from remote to local.

8.2 ACTUAL VALUES

These input values display the current status of the Thyro-P.

Table 13.3 lists all the available actual values.

8.3 FUNCTIONS

Certain functions in Thyro-P can be carried out via this output word, whereby this can also take place acyclically via DPV1 (see Table 13.15).

BIT	PURPOSE	CONTROL
0	Control lock	Static
1	Ext. fault indication	
2	Use output data	
3-7	Reserved	
8	Acknowledge error	Jump triggered
9	Reset	
10	Save	
11	Reset Energie Indication	
12-15	Reserved	

TAB. 8.2 FUNCTIONS

Static:

Is set when the relevant bit is set to 1.

Jump trigger:

Is triggered when the relevant bit is set from 0 to 1.

Acknowledge error:

By setting the register to 1 a signal can be acknowledged. When the function has been carried out the register is set back to zero.

Reset:

By setting the register to 1 the Thyro-P's control device can be reset. The bus card, however, is not reset. When the function has been carried out the register is reset to zero.

Save:

By setting the register to 1 all settings can be saved. Then Thyro-P will start with the most recent settings. The controller lock is also saved. After the function has been carried out the register is reset to zero.

Reset Energie Indication: By setting this Bit to 1 the energie will be reset.



ATTENTION

After transmitting the order to save, no parameters may be changed for 3 seconds.

Controller lock:

By setting the register to 1 (controller lock = ON) the controller lock can be activated. By setting to zero it is deactivated again.

Ext. fault indication:

By setting or resetting this register, an external signal can be triggered in the Thyro-P. Via this function the relays or LEDs can be controlled (see Thyro-P instructions).

8.4 MODULES

The parameters of the Thyro-P (see Table 13.4 to Table 13.15) can be read or written cyclically via this input and output data. Hereby the slot number (0-12) and the index (0-48) of the corresponding parameter must always be given.

9. ACYCLIC DATA TRANSMISSION (PARAMETERIZATION)

Via the acyclic parameter data transmission, parameters of the devices can be changed or selected. Cyclical and acyclical services can be used in the network simultaneously.

READ DATA RECORD "RDREC"

For reading access to a data record, the slot, index and length of the data record must be entered. At step 7 and when using the SFB 52 the logical address of the slot is to be entered instead of the slot. However, as multiple slots are occupied by the same controller, here the slot of the master setpoint or its logical address is to be given.

ERROR CODE	MEANING
DE80B000	The unit does not recognize the parameter (invalid index)
DE80B100	The length entry of the parameter is incorrect
DE80B200	The projected slot is not occupied
DE80B300	The actual unit type does not match the set unit type

WRITE DATA RECORD "WRREC"

For writing access to a data record, the slot, index, length of the data record and the new value must be entered. At step 7 and when using the SFB 53 the logical address of the slot is to be entered instead of the slot. However, as multiple slots are occupied by the same controller, here the slot of the master setpoint or its logical address is to be given.

ERROR CODE	MEANING
DE80B000	The unit does not recognize the parameter (invalid index)
DE80B100	The length entry of the parameter is incorrect
DE80B200	The projected slot is not occupied
DE80B300	The actual unit type does not match the set unit type
DF80B600	The parameter cannot be changed
DF80B700	Invalid range of values of a parameter

10. DIAGNOSIS INDICATIONS

Should a fault occur, the Thyro-P sends a device-specific diagnosis to the master.

VALUE	DEFINITION
...	Telegram header
06	Length of device-specific diagnosis
a0	Header of device-specific diagnosis
00	"
00	"
??	Status Hi-Byte (Table 10.2)
??	Status Low-Byte (Table 10.2)
...	Telegram end

TAB. 10.1 SET UP OF DIAGNOSIS DIAGRAM

The status word (2 bytes) is transmitted with the diagnosis indication. Each bit corresponds to a signal which indicates the current status of the Thyro-P. Further information on the individual values can be found in the instructions to Thyro-P.

Each of these signals can be deactivated via the parameterization programme (see Section 6.2), so that they are no longer shown via the diagnosis signal.

The latest status can, however, still be read out (see Table 13.3).

BIT	STATUS
15	MOSI in peak current limit
14	SYNC fault
13	Overvoltage in mains
12	Undervoltage in mains
11	Overcurrent in load circuit
10	Undercurrent in load circuit
9	Controller lock
8	Excess temperature
7	Limit
6	U limit
5	I limit
4	P limit
3	Impulse cut-off
2	Sensor breakdown - short circuit
1	Res.
0	SSC fault

TAB. 10.2 SET UP OF THE WORD'S ACTUAL STATUS

On disturbances of communication between PROFIBUS DPV1 interface card and Thyro-P, the "static diagnosis" is released, and the message "SSC error" transfer. It is then no data exchange between master and Slave possible. This error knows on the fact that e.g. the PROFIBUS DPV1 interface card correctly does not sit in the slot.

11. DIGITAL INPUTS

Via the 9-pole sub-D bushing (X21) the PROFIBUS DPV1 interface card provides access to three digital inputs as well as one input to activate the local operation (see Section 12). They are automatically displayed on the PROFIBUS (see Table 13.3 index 81).

PIN	DESIGNATION	FUNCTION
1	Earth	Earth
2	M1	Ground for IN0 and IN1
3	IN 0	Input 0
4	IN 1	Input 1
5	M24	Ground/internal 24 V supply
6	M2	Ground for IN2 and IN3
7	IN 2	Input 2
8	Loc	Input 3
9	+24	+24 V/internal 24 V supply

TAB. 11.1 CONNECTION ALLOCATION X21

Hereby inputs 0 and 1 always refer to ground M1 and the inputs 2 and Loc refer to ground M2. For connection to simple indicators such as limiter switches an additional 24V supply is also available.

Here the following connection would be possible:

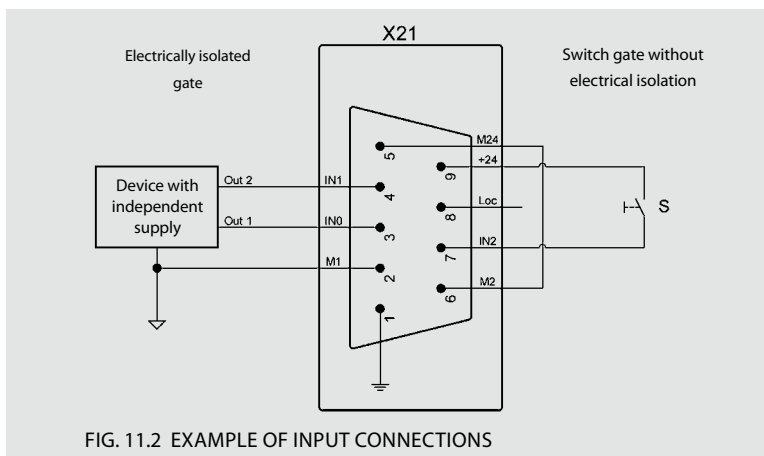

FIG. 11.2 EXAMPLE OF INPUT CONNECTIONS

12. LOCAL OPERATION OF THE MOTORPOTI SETPOINT

In certain situations, for example failure of the PROFIBUS, it can in some cases be necessary to change the setpoint quickly. Although this is possible via the LBA-2, it can be too involved for certain applications.

In order to overcome this drawback, the option of operating Motorpoti locally with push buttons was created.

Local operation of the Motorpoti setpoint can be activated via the input Loc (Pin 8). It is then possible to switch the value SW_ACTIV between remote (open) and local (closed) via the input INO (Pin 3). The Motorpoti set value can now be changed in local modus via the inputs IN1 and IN2, whereby the setpoint changes when the switch is pressed down as in Fig. 12.1. E.g. the setpoint is increased by 30% when the UP key is pressed down for 10 seconds. If the Up and Down keys are pressed simultaneously the setpoint is reduced.

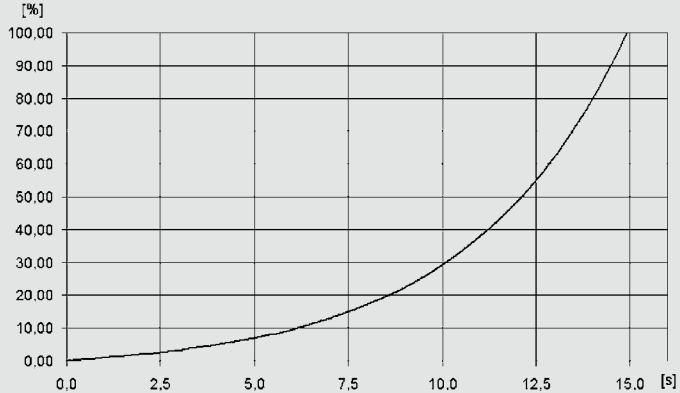

FIG. 12.1 RELATIVE CHANGE OF THE MOTORPOTI SETPOINT OVER TIME

For local operation the connector X21 is to be connected as follows:

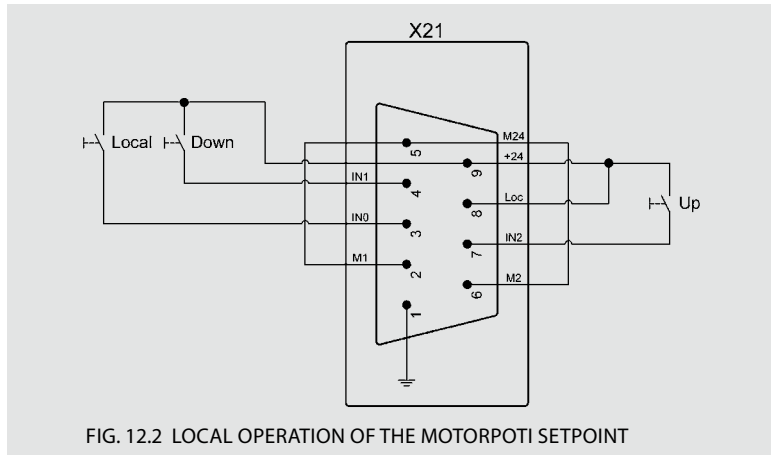
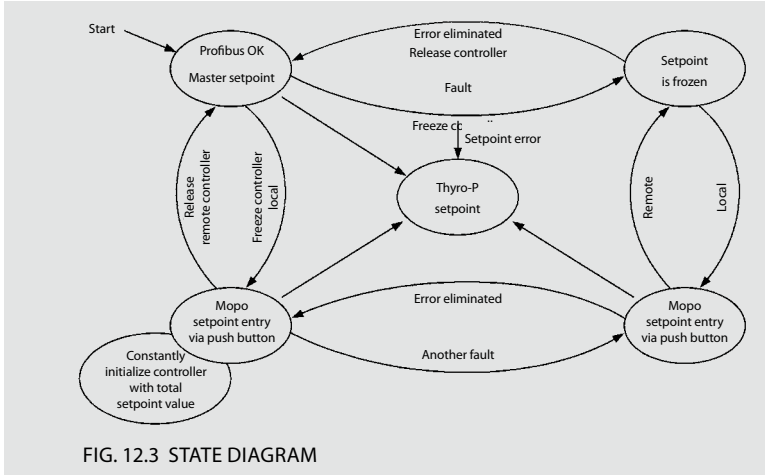

FIG. 12.2 LOCAL OPERATION OF THE MOTORPOTI SETPOINT

Attention: When applying the local operation the following points must be observed:

1. To avoid a sudden change in the setpoint when switching from remote to local, the „Motorpoti setpoint“ in remote operation must be set to equal the „master setpoint“ (see Section 6.2)
2. With „local“ switched off („4 digital inputs“ bit 0 = 0) the process controller must be deactivated and the „master setpoint“ set equal to the „total setpoint value“ in order to ensure a smooth switch from local to remote. For this the total setpoint value is to be transmitted cyclically.
3. When switching from local to remote the process controller must be initialized with the total setpoint value and then activated. The following flow-chart represents the above settings (see Fig. 12.3).



13. SETPOINT VALUES, ACTUAL VALUES AND PARAMETERS

All data of the Thyro-P (setpoint values, actual values and parameters) can either be read or changed cyclically (see Section 8) or acyclically (DPV1). All the data is listed in the following tables. With acyclic communication the slot number and index must always be provided.

INDEX	SETPOINT	TYPE	SIZE	UNIT	R/W
0	Setpoint master	integer	1	16383 == 100[%]	r/w
1	Setpoint master Error	integer	1	16383 == 100[%]	r/w
2	Setpoint Motorpoti	integer	1	16383 == 100[%]	r/w
3	Empty	-	1	-	r
4	Setpoint master	float	2	[W,V,A,%]	r/w
6	Setpoint master error	float	2	[W,V,A,%]	r/w
8	Setpoint Motorpoti	float	2	[W,V,A,%]	r/w
10	Empty	-	2	-	r

TAB. 13.1 SETPOINT VALUES (SLOT 0)

INDEX	FUNCTION	TYPE	SIZE	UNIT	R/W
12	Functions	integer	1	See Tab. 8.2	w
13	Empty	-	3	-	r

TAB. 13.2 FUNCTIONS (SLOT 0)

INDEX	ACTUAL VALUES	TYPE	SIZE	UNIT	R/W
16	Output L1	float	2	[W]	r
18	Voltage L1	float	2	[V]	r
20	Current L1	float	2	[A]	r
22	Load L1	float	2	[S]	r
24	Supply voltage L1	float	2	[V]	r
26	Empty	-	6	-	r
32	Output L2	float	2	[W]	r
34	Voltage L2	float	2	[V]	r
36	Current L2	float	2	[A]	r
38	Load L2	float	2	[S]	r
40	Supply voltage L2	float	2	[V]	r
42	Empty	-	6	-	r
48	Output L3	float	2	[W]	r
50	Voltage L3	float	2	[V]	r
52	Current L3	float	2	[A]	r
54	Load L3	float	2	[S]	r
56	Supply voltage L3	float	2	[V]	r
58	Empty	-	6	-	r
64	Total output	float	2	[W]	r
66	Temperature	float	2	[°C]	r
68	Total setpoint	float	2	[W, V, A, %]	r
70	Setpoint Mopo	float	2	[W, V, A, %]	r
72	Total setpoint	integer	1	16383 == 100[%]	r
73	Setpoint Mopo	integer	1	16383 == 100[%]	r
74	Setpoint terminal 10	integer	1	16383 == 100[%]	r
75	Setpoint terminal 11	integer	1	16383 == 100[%]	r
76	Setpoint activated	integer	1	-	r
77	Connection angle alpha	integer	1	18000 == 180°el	r
78	Actual value connection time	integer	1	[period]	r
79	Period duration	integer	1	[µs]	r
80	LED and relay status	integer	1	-	r
81	Digital inputs	integer	1	4 Bit	r
82	Operating hour	float	2	[h]	r
84	Energy	float	2	[kWh]	r
86	Empty	-	2	-	r
88	Status	integer	1	See Table 10.2	r
89	Empty	-	15	-	r

TAB. 13.3 ACTUAL VALUES (SLOT 0)

INDEX	SYMBOL	NAME	VALUE RANGE	COMBO-OPT	UNIT	R/W	DEFAULT
0	BETR	Operating mode	0..2	TAKT, VAR, SSSD		r/w	TAKT
1	MOSI	Oper. of molybdenum disilicide rods	0..2	OFF, RAMP, CONTR.		r/w	OFF
2	SEB	Service operation	0..1	OFF, ON		r/w	OFF
3	ASM	Automatic synchronisation for multi- ple controller applications	0..1	OFF, ON		r	OFF
4	ASM_SUMM	ASM total current	1..65535		[A]	r/w	65000
5	TYP	Number of controlled phases	1..3			r/w	1 phase
6	NLT	Zero conductor	0..1	OFF, ON		r/w	OFF
7	NACHIMP	Afterpulse	0..1	OFF, ON		r/w	
8	SCHW	Phase variation	0..1	OFF, ON		r/w	
9	SCHW_POL	Phase variation, polarity	0..1	PLUS, MINUS		r/w	plus
10	SCHW_L1	Phase variation L1	0..360°el		0.01 °el	r/w	0
11	SCHW_L2	Phase variation L2	0..360°el		0.01 °el	r/w	0
12	SCHW_L3	Phase variation L3	0..360°el		0.01 °el	r/w	0
13	SYNC_ANZ	Number of sync voltages	1..3			r/w	
14	SYNC_DREHF	Cyclic field	0..1	right, left		r/w	right
15	KANALTREN	Channel separation	0..1	OFF, ON		r/w	ON

TAB. 13.4 OPERATING MODE (SLOT 1)

INDEX	SYMBOL	NAME	VALUE RANGE	COMBO-OPT	UNIT	R/W	DEFAULT
0	AN1	Phase angle of first half wave	0..180°el		0.01 °el	r/w	60°el
1	SST	Softstart duration (given)	0..9980 ms		20 ms	r/w	120 ms
2	SDN	Softdown duration (given)	0..9980 ms		20 ms	r/w	120 ms
3	T ₀	Pulse period duration	0..T ₀ _MAX		20 ms	r/w	1 s
4	T ₀ _MAX	Pulse period duration maximum	02..1310 s		20 ms	r/w	5 s
5	TSMAX	Max. pulse connection time	0..T ₀		20 ms	r/w	1 s
6	TSMIN	Min. pulse connection time	0..T ₀		20 ms	r/w	0 ms
7	MP	Minimum pause	0..200 ms		20 ms	r/w	
8	SYNC_EXT	Synchronous phase internal/external	0..1	Intern, Extern		r	internal
9	SYNC_ADR	Synchronous phase address	0..655350 ms		10 ms	r/w	1 ms

TAB. 13.5 DURATIONS (SLOT 2)

INDEX	SYMBOL	NAME	VALUE RANGE	COMBO-OPT	UNIT	R/W	DEFAULT
0	RE	Control	0..8	Uload ² , Uload eff, Iload ² , Iload eff, output, res., res., res., Without control		r/w	Uload ²
1	STD_RE	Standard controller	0..1	OFF, ON		r/w	ON
2	TI_1	PID controller, I part	0 = off 0..65535			r/w	800
3	KP_1	PID controller, P part	0 = off 0..65535			r/w	160
4	KR_1	PID controller, counter, P part	0..65535			r/w	1
5	TD_1	PID controller, D part	0 = off 0..65535			r/w	0
6	TI_1_STD	PID controller, I part, Standard value	0 = off 0..65535			r	800
7	KP_1_STD	PID controller, P part, Standard value	0 = off 0..65535			r	160
8	KR_1_STD	PID controller, counter P part, Standard value	0..65535			r	1
9	TD_1_STD	PID controller, D part, Standard value	0 = off 0..65535			r	0
10	MOSI_WL_GE_1	Angle change speed 1	0..65535			r/w	1100
11	MOSI_WL_GE_2	Angle change speed 2	0..65535			r/w	50

TAB. 13.6 CONTROL (SLOT 3)

INDEX	SYMBOL	NAME	VALUE RANGE	COMBO-OPT	UNIT	R/W	DEFAULT
0	UEMI	Effective voltage setpoint minimum	0..65535 V		V	r / w	0V
1	UEMA	Effective voltage setpoint maximum	0..65535 V		V	r / w	440V
2	IEMI	Effective current setpoint minimum	0..65535 A		A	r / w	0A
3	IEMA	Effective current setpoint maximum	0..65535 A		A	r / w	110A
4	PMI_H	Output setpoint minimum hi	0..65535 xW		65536W	r / w	0W
5	PMI_L	Output setpoint minimum low	0..65535 W		W	r / w	0W
6	PMA_H	Output setpoint max. hi	0..65535 xW		65536W	r / w	0W
7	PMA_L	Output setpoint max. low	0..65535 W		W	r / w	48400 W
8	V_IE	Front impulse stop	0..180°el		0.01°el	r / w	180°el
9	H_IE	Back impulse stop	0..180°el		0.01°el	r / w	0°el

TAB. 13.7 LIMIT (SLOT 4)

INDEX	SYMBOL	NAME	VALUE RANGE	COMBO-OPT	UNIT	R/W	DEFAULT
0	SW_ACTIV	Setpoint activation	0..15	Bit 0 = 1 (setpoint terminal 10 active) etc.		r/w	15
1	SW	Setpoint switch	0..3	_ADD, IADD, _PRO, IPRO		r/w	_ADD
2	MOSI_IS_FA	Factor peak current limit	0..1000			r/w	25
3	SW_SPRUNG	Setpoint jump correction	0..1	OFF, ON		r/w	ON
4	SW_INP_IU_10	Input voltage/current terminal 10	0..2	5 V, 10 V, 20 mA		r/w	20 mA
5	STA_REGLER	Start trigger regul. Input terminal 10	depending on SW_INP_IU_10		0.3 mV 0.6 mV 1.22 uA	r/w	292 uA (240)
6	STE_REGLER	End trigger regul. Input terminal 10	depending on SW_INP_IU_10		0.3 mV 0.6 mV 1.22 uA	r/w	20 mA (16383)
7	SW_INP_IU_11	Input voltage/ current terminal 11	0..2	5 V, 10 V, 20 mA		r/w	5 V
8	STA_POTI	Start trigger regul. Input terminal 10	depending on SW_INP_IU_11		0.3 mV 0.6 mV 1.22 uA	r/w	72 mV (240)
9	STE_POTI	End trigger regul. Input terminal 11	depending on SW_INP_IU_11		0.3 mV 0.6 mV 1.22 uA	r/w	5 V (16383)
10	STA_MASTER	Start trigger master	0..100%		0.0061%	r/w	0%
11	STE_MASTER	End trigger master	0..100%		0.0061%	r/w	100% (16383)
12	STA_MOPO	Start trigger master Motorpoti	0..100%		0.0061%	r/w	0%
13	STE_MOPO	End trigger Motorpoti	0..100%		0.0061%	r/w	100% (16383)

TAB. 13.8 CONTROL CHARACTERISTICS (SLOT 5)

INDEX	SYMBOL	NAME	VALUE RANGE	COMBO-OPT	UNIT	R/W	DEFAULT
0	TEMP	Temperature probe	0..3	none, Pt100, PT1000, NTC		r/w	none
1	TEMP_KVE	Characteristic number	0..7	characteristic 0 ... characteristic 7		r/w	
2	FU_DR_BR	Level line break	0..4000		Ohm	r/w	
3	FU_KURZ	Level short circuit	0..4000		Ohm	r/w	
4	TEMP_FE_DAU	Temperature fault duration	1..1000		20 ms	r/w	10

TAB. 13.9 TEMPERATURE (SLOT 6)

INDEX	SYMBOL	NAME	VALUE RANGE	COMBO-OPT	UNIT	R/W	DEFAULT
0	MITTEL	Establ. average mean	0..1000			r/w	25
1	IST_1	Actual value output 1	0..1	20 mA, 10 V		r/w	20 mA
2	OF_1	Offset 1	0..20000 uA		uA	r/w	0 uA
3	DAC1_VA_U	Measuring device end-scale deflection DAC1, voltage	0..10000 mV		mV	r/w	10 V
4	DAC1_VA_I	Measuring device end-scale deflection DAC1, current	0..20000 uA		uA	r/w	20 mA
5	DAC_1_CTRL	Configuration register analog output 1	bitwise			r/w	18
6	U_FA_1	Scale end value voltage actual value output 1	0..65535 V		V	r/w	150 A
7	I_FA_1	Scale end value current actual value output 1	0..65535 A		A	r/w	500 V
8	P_FA_1_H	Scale end value output actual value output 1	0..65535xW		xW	r/w	0 W
9	P_FA_1_L	Scale end value output actual value output 1	0..65535W		W	r/w	50000W
10	ALPHA_FA_1	Scale end value alpha actual value output 1	0..180°el		.01°el	r/w	180°el
11	IST_2	Actual value output 2	0..1	20 mA, 10V		r/w	20mA
12	OF_2	Offset 2	0..20000uA		uA	r/w	0uA
13	DAC2_VA_U	Measuring device end-scale deflection DAC2, voltage	0..10000mV		mV	r/w	10V
14	DAC2_VA_I	Measuring device end-scale deflection DAC2, current	0..20000uA		uA	r/w	20mA
15	DAC_2_CTRL	Configuration register analogue output 2	bitwise			r/w	18
16	U_FA_2	Scale end value voltage actual value output 2	0..65535 V		V	r/w	500 V
17	I_FA_2	Scale end value current actual value output 2	0..65535 A		A	r/w	150 A
18	P_FA_2_H	Scale end value output actual value output 2	0..65535xW		xW	r/w	0 W
19	P_FA_2_L	Scale end value output actual value output 2	0..65535W		W	r/w	50000 W
20	ALPHA_FA_2	Scale end value alpha actual value output 2	0..180°el		.01°el	r/w	180°el
21	IST_3	Actual value output 3	0..1	20 mA, 10 V		r/w	20 mA
22	OF_3	Offset 3	0..20000uA		uA	r/w	0 uA
23	DAC3_VA_U	Measuring device end-scale deflection DAC3, voltage	0..10000mV		mV	r/w	10 V
24	DAC3_VA_I	Measuring device end-scale deflection DAC3, current	0..20000uA		uA	r/w	20 mA
25	DAC_3_CTRL	Configuration register analogue output 3	bitwise			r/w	18
26	U_FA_3	Scale end value voltage actual value output 3	0..65535 V		V	r/w	500 V
27	I_FA_3	Scale end value current actual value output 3	0..65535 A		A	r/w	150 A
28	P_FA_3_H	Scale end value output actual value output 3	0..65535xW		xW	r/w	0 W
29	P_FA_3_L	Scale end value output actual value output 3	0..65535W		W	r/w	50000 W
30	ALPHA_FA_3	Scale end value alpha actual value output 3	0..180°el		.01°el	r/w	180°el

TAB. 13.10 ANALOGUE OUTPUTS (SLOT 7)

INDEX	SYMBOL	NAME	VALUE RANGE	COMBO-OPT	UNIT	R/W	DEFAULT
0	I_TYP	Controller type current	0..65535A		A	r/w	110 A
1	I_TYP_LSB	Type current in LSB	0..65535			r	
2	UE_I	Current transformer conversion	0..65535			r/w	100
3	R_BUERDE_I	Load resistance current	0..653 Ohm		.01 Ohm	r/w	0.91 Ohm
4	NORM_I	Scaling factor current	0..65535			r/w	
5	I_SCHW	Current value threshold	0..65535		0.1 A	r/w	6500 A
6	U_TYP	Controller mains voltage	0..1000V		V	r/w	400 V
7	U_TYP_LSB	Type voltage in LSB	0..65535			r	
8	U_NETZ_ANW	Supply voltage user	0..1000V		V	r/w	400 V
9	UE_U	Voltage transformer conversion	0..1000			r/w	16
10	TYP_BEREICH	Voltage range switch	0..2	230 V, 400 V, 690 V		r/w	400 V
11	R_BUERDE_U	Load resistance voltage	0..65535 Ohm		Ohm	r/w	1680 Ohm
12	R_BUERDE_U_1	Load resistance voltage area 1	0..65535 Ohm		Ohm	r/w	1680 Ohm
13	R_BUERDE_U_2	Load resistance voltage area 2	0..65535 Ohm		Ohm	r/w	1680 Ohm
14	U_NORM_230	Scaling factor 230V	0..65535			r/w	
15	U_NORM_400	Scaling factor 400V	0..65535			r/w	
16	U_NORM_690	Scaling factor 500 V-690 V	0..65535			r/w	
17	FREQ_MIN	Minimum frequency	14286..25000, 1/X * 10^6		Hz	r/w	22222 (45 Hz)
18	FREQ_MAX	Maximum frequency	14286..25000, 1/X * 10^6		Hz	r/w	15151 (66 Hz)
19	FREQ_TOL	Frequency tolerance	0..100		%	r/w	10%
20	P_TYP_H	Controller type output Hi	0..65535xW		xW	r/w	0 W
21	P_TYP_L	Controller type output Lo	0..65535W		W	r/w	44000W
22	P_TYP_LSB_H	Type output Hi in LSB	0..65535x			r	
23	P_TYP_LSB_L	Type output Lo in LSB	0..65535			r	
24	TI_FA	Poti controller parameters Ti	0..65535			r/w	0
25	KP_FA	Poti controller parameters Kp	0..65535			r/w	0
26	R_TEIL	Voltage divider resistance	0..65535		Ohm	r/w	36000
27	MESS	Test switch	0..5	Aron, 1/2 Aron 1, 1/2 Aron 2, 1/2 Aron 3, asymmetrical load, symmetrical load			

TAB. 13.11 HARDWARE PARAMETERS (SLOT 8)

INDEX	SYMBOL	NAME	VALUE RANGE	COMBO-OPT	UNIT	R/W	DEFAULT
0	SPG_MIN	Power monitor circuit minimum	0..1000 V		V	r/w	
1	SPG_MAX	Power monitor circuit maximum	0..1000 V		V	r/w	
2	UN_S	Undercurrent monitoring	0..1	OFF, ON		r/w	OFF
3	UE_S	Overcurrent monitoring	0..1	OFF, ON		r/w	OFF
4	REL_ABS	Load fault	0..1	REL_, ABS		r/w	REL_
5	LASTBRUCH_M IN	Load fault, minimum value	0..99%		%	r/w	0%
6	LASTBRUCH_M AX	Load fault, maximum value	101...255%		%	r/w	0%
7	LASTBRUCH_M IN_ABS	Load fault, minimum value	0..65535			r/w	0
8	LASTBRUCH_M AX_ABS	Load fault, maximum value	0..65535			r/w	0
9	L2_ENA	Monitoring L2 Enable	0..1	OFF, ON		r/w	OFF
10	L3_ENA	Monitoring L3 Enable	0..1	OFF, ON		r/w	OFF

TAB. 13.12 MONITORING (SLOT 9)

INDEX	SYMBOL	NAME	VALUE RANGE	COMBO-OPT	UNIT	R/W	DEFAULT
0	K1RU	LED & relay working principle	0..256, bitwise	Operating current principle Zero signal current principle		r/w	
1	OUT0_CFG	LED CONTROL Mode	0..65535			r/w	
2	OUT1_CFG	LED LIMIT Mode	0..65535			r/w	
3	OUT2_CFG	LED PULSE LOCK Mode	0..65535			r/w	
4	OUT3_CFG	LED FAULT Mode	0..65535			r/w	
5	OUT4_CFG	LED OVERHEAT Mode	0..65535			r/w	
6	OUT5_CFG	Relay K1 Mode	0..65535			r/w	
7	OUT6_CFG	Relay K2 Mode	0..65535			r/w	
8	OUT7_CFG	Relay K3 Mode	0..65535			r/w	
9	OUT0_ STOERM_L	LED CONTROL config. 0	0..65535			r/w	
10	OUT1_ STOERM_L	LED LIMIT config. 0	0..65535			r/w	
11	OUT2_ STOERM_L	LED PULSE LOCK config. 0	0..65535			r/w	
12	OUT3_ STOERM_L	LED FAULT config. 0	0..65535			r/w	
13	OUT4_ STOERM_L	LED OVERHEAT config. 0	0..65535			r/w	
14	OUT5_ STOERM_L	Relay K1 config. 0	0..65535			r/w	
15	OUT6_ STOERM_L	Relay K2 config. 0	0..65535			r/w	
16	OUT7_ STOERM_L	Relay K3 config. 0	0..65535			r/w	
17	OUT0_ STOERM_H	LED CONTROL config. 1	0..65535			r/w	
18	OUT1_ STOERM_H	LED LIMIT config. 1	0..65535			r/w	
19	OUT2_ STOERM_H	LED PULSE LOCK config. 1	0..65535			r/w	
20	OUT3_ STOERM_H	LED FAULT config. 1	0..65535			r/w	
21	OUT4_ STOERM_H	LED OVERHEAT config. 1	0..65535			r/w	
22	OUT5_ STOERM_H	Relay K1 config. 1	0..65535			r/w	
23	OUT6_ STOERM_H	Relay K2 config. 1	0..65535			r/w	
24	OUT7_ STOERM_H	Relay K3 config. 1	0..65535			r/w	

TAB. 13.13 LEDS AND RELAYS (SLOT 10)

INDEX	SYMBOL	NAME	VALUE RANGE	COMBO-OPT	UNIT	R/W	DEFAULT
0	DA_EN_2	Data logger Enable Register Hi	0..65535			r/w	
1	DA_EN_1	Data logger Enable Register Low	0..65535			r/w	
2	RESET_2	Reset trigger with fault Hi	0..65535			r/w	
3	RESET_1	Reset trigger with fault Low	0..65535			r/w	
4	IMAB_2	Impulse cutoff with fault Hi	0..65535			r/w	
5	IMAB_1	Impulse cutoff with fault Low	0..65535			r/w	
6	VERS_J	Version year	0..9999			r	
7	VERS_M	Version month	1..12			r	
8	VERS_T	Version day	1..31			r	
9		Bus card version year	0..9999			r	
10		Bus card version month	1..12			r	
11		Bus card version day	1..31			r	
12	USER_PARA_0	User parameter 0	0..65535			r/w	
13	USER_PARA_1	User parameter 1	0..65535			r/w	
14	USER_PARA_2	User parameter 2	0..65535			r/w	
15	USER_PARA_3	User parameter 3	0..65535			r/w	
16	USER_PARA_4	User parameter 4	0..65535			r/w	
17	USER_PARA_5	User parameter 5	0..65535			r/w	
18	USER_PARA_6	User parameter 6	0..65535			r/w	
19	USER_PARA_7	User parameter 7	0..65535			r/w	
20	USER_PARA_8	User parameter 8	0..65535			r/w	
21	USER_PARA_9	User parameter 9	0..65535			r/w	
22	USER_PARA_10	User parameter 10	0..65535			r/w	
23	USER_PARA_11	User parameter 11	0..65535			r/w	
24	USER_PARA_12	User parameter 12	0..65535			r/w	
25	USER_PARA_13	User parameter 13	0..65535			r/w	
26	USER_PARA_14	User parameter 14	0..65535			r/w	

TAB. 13.14 OTHER (SLOT 11)

INDEX	SYMBOL	NAME	VALUE RANGE	COMBO-OPT	UNIT	R/W	DEFAULT
0		Acknowledge fault	0..1	OFF, QUIT		r/w	OFF
1		Reset	0..1	OFF, RESET		r/w	OFF
2		Save	0..1	OFF, SAVE		r/w	OFF
3		Controller lock	0..1	OFF, ON		r/w	OFF
4		External fault indication	0..1	OFF, ON		r/w	OFF

TAB. 13.15 FUNCTIONS (SLOT 12)



World Headquarters
1625 Sharp Point Drive
Fort Collins, CO 80525 USA

970.221.4670 Main
970.221.5583 Fax

www.advanced-energy.com

Specifications are subject to change without notice.

© 2014 Advanced Energy Industries, Inc. All rights reserved. Advanced Energy® and Thyro-P™ are trademarks of Advanced Energy Industries, Inc.

