



INTERFACE CARD MODBUS RTU

FORTHYRO-P AND THYRO-P MC

July 2014

DE/EN - V3

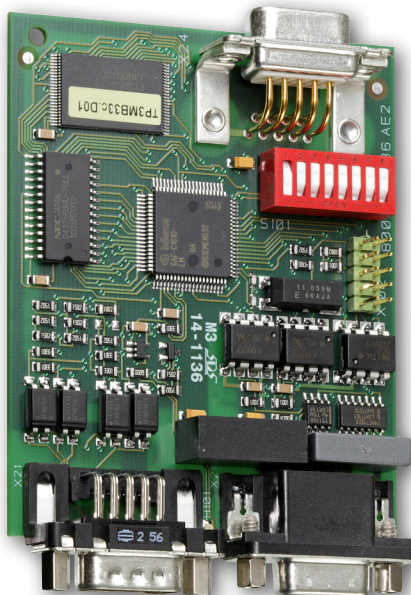

CONTACT INFORMATION

TECHNICAL QUERIES

Do you have any technical queries regarding the subjects dealt with in these operating instructions?

If so, please get in touch with our team for power controllers:

Phone +49 (0) 2902 763-520

COMMERCIAL QUERIES

Do you have any commercial queries on power controllers?

If so, please get in touch with our team for power controllers.

Phone +49 (0) 2902 763-558

SERVICE

Advanced Energy Industries GmbH

Branch Office Warstein-Belecke

Emil-Siepmann-Straße 32

D-59581 Warstein

Phone +49 (0) 2902 763-0

<http://www.advanced-energy.com>

COPYRIGHT

No part of these operating instructions may be transmitted, reproduced and/or copied by any electronic or mechanical means without the express prior written permission of Advanced Energy.

© Copyright Advanced Energy Industries GmbH 2014.

All rights reserved.

FURTHER INFORMATION ON COPYRIGHT

Thyro™, Thyro-P™ are registered trademark of Advanced Energy Industries GmbH.

All other company and product names are (registered) trademarks of the respective owners.

TABLE OF CONTENTS

1. Introduction	5
2. Safety	7
2.1 Identification in the operating instructions	7
2.2 General danger information	8
2.3 Operator requirements	9
2.4 Personnel requirements	9
2.5 Intended purpose	9
2.6 Use of the device	10
3. Configuration	11
3.1 Adjust the address	11
3.2 Configure the transfer parameter	11
4. Installation	13
5. Modbus-/J-Bus-Communication	14
5.1 Read Holding Registers (0x03)	14
5.2 Preset Single Register (0x06)	15
5.3 Preset Multiple Regs (0x10)	16
5.4 Report Slave ID (0x11)	17
5.5 Exception Respons	17
6. Functions	18
7. Status messages	19
8. Digitale inputs	20
9. Local operation of the Setpoint Motorpoti	22
10. Register	24
10.1 Setpoints	24
10.2 Actual values	26
10.3 Parameters	27

LIST OF ILLUSTRATIONS AND TABLES

Fig. 1.1	Modbus RTU interface card	5
Fig. 1.2	Pin allocation of the Modbus socket	6
Fig. 3.1	Configuration switch	11
Fig. 8.2	Example of connecting inputs	22
Fig. 9.1	Local operation of the Setpoint Motorpoti	23
Tab. 3.1	Allocation of the configuration switch	12
Tab. 4.1	State of diagnostic-LED	13
Tab. 6.1	Functions	18
Tab. 7.1	Status messages	19
Tab. 8.1	Connection assignment X21	20
Tab. 10.1	Register: Setpoints	24
Tab. 10.2	Register: Actual values	26
Tab. 10.3	Register: Operating Mode	27
Tab. 10.4	Register: Times	27
Tab. 10.5	Register: Controls	28
Tab. 10.6	Register: Limit	28
Tab. 10.7	Register: Control characteristic	29
Tab. 10.8	Register: Temperature	29
Tab. 10.9	Register: Analog outputs	30
Tab. 10.10	Register: Hardware parameter	31
Tab. 10.11	Register: Monitoring	32
Tab. 10.12	Register: LED & Relays	33
Tab. 10.13	Register: Miscellaneous	34
Tab. 10.14	Register: Functions	34

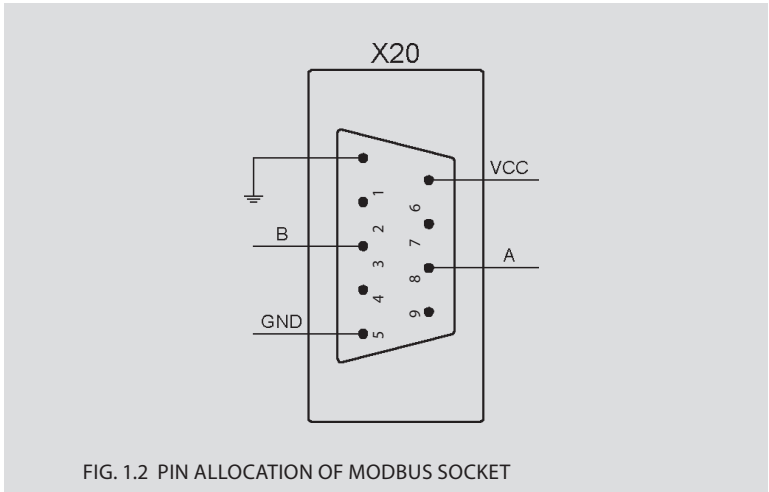

2. SAFETY

2.1 IDENTIFICATION IN THE OPERATING INSTRUCTIONS

In these operating instructions, there are warnings before dangerous actions. These warnings are divided into the following danger categories:



DANGER

Dangers that can lead to serious injuries or fatal injuries.



WARNING

Dangers that can lead to serious injuries or considerable damage to property.



CAUTION

Dangers that can lead to injuries and damage to property.



CAUTION

Dangers that can lead to minor damage to property.

The warnings can also be supplemented with a special danger symbol (e.g. „Electric current“ or „Hot parts“), e.g.



risk of electric current or



risk of burns.

In addition to the warnings, there is also a general note for useful information.



NOTE

Content of note

2.2 GENERAL DANGER INFORMATION



DANGER

Failure to observe the safety regulations in the operating instructions for the power controllers used risk of injury or damage to the device or plant.

- > Observe all safety regulations in the safety chapter of the operating instructions for the power controllers used.



DANGER

Electric current

Risk of injury from live parts/risk of damage to the bus module

- Never operate the device without the cover.
- Only carry out adjustments or wiring when the device is deenergised.



CAUTION

Risk of damage to the interface card

The current at terminals X1.5 to X8.5 may not exceed 120 mA.

- > Check the connection data of the upstream relay.



NOTE

Communication faults

To avoid communication faults, observe the following points:

- > Use shielded cables.
- > Ensure grounding on the bus module (X1.7 to X8.7). Do not also ground on the power controller.

2.3 OPERATOR REQUIREMENTS

The operator must ensure the following:

- That the safety regulations of the operating instructions are observed.
- That the accident prevention regulations valid in the respective country of use and the general safety regulations are observed.
- That all safety devices (covers, warning signs etc.) are present, in perfect condition and are used correctly.
- That national and regional safety regulations are observed.
- That the personnel has access to the operating instructions and safety regulations at all times.
- That operating conditions and restrictions resulting from the technical data are observed.
- That, should abnormal voltages, noises, increased temperatures, vibration or similar occur, the device is immediately put out of operation and the maintenance personnel is informed.

2.4 PERSONNEL REQUIREMENTS

Only qualified electro-technical personnel who are familiar with the pertinent safety and installation regulations may perform the following:

- Transport
- Installation
- Connection
- Start-up
- Maintenance
- Testing
- Operation.

These operating instructions must be read carefully by all persons working with or on the equipment prior to installation and initial start-up.

2.5 INTENDED PURPOSE

The device may only be used for the purpose for which it was intended, as persons may otherwise be exposed to dangers (e.g. electric shock, burns) and plants also (e.g. overload). The user must therefore observe the following points:

- It is not permitted to make any unauthorised modifications to the unit or to use any spare parts or replacement parts not approved by Advanced Energy, or to use the unit for any other purpose.

- The warranty obligations of the manufacturer are only applicable if these operating instructions are observed and complied with.
- The device is a component that cannot function alone.
- Project planning must account for the proper use of the device.

2.6 USE OF THE DEVICE

2.6.1 OPERATION

- Only switch on the mains voltage at the machine when there is no danger to persons, system or load.
- Protect the device against dust and damp.
- Ensure that the ventilation openings are not blocked.

2.6.2 PRIOR TO INSTALLATION/START-UP

- If stored in a cold environment: ensure that the device is absolutely dry. (Allow the device a period of at least two hours to acclimatise before start-up.)
- Ensure sufficient ventilation of the cubicle if mounted in a cubicle.
- Observe minimum spacing.
- Ensure that the device cannot be heated up by heat sources below it.
- Ground the device in accordance with local regulations.
- Connect the device in accordance with the connection diagram.

2.6.3 MAINTENANCE, SERVICE, FAULTS

In order to avoid injuries and damage, the user must observe the following:

- Before all work:
 - > Disconnect the device from all external voltage sources.
 - > Secure the device against accidentally being switched back on.
 - > Use suitable measuring instruments and check that there is no voltage present.
 - > Ground and short-circuit the device.
 - > Provide protection by covers or barriers for any neighbouring live parts.
- The device may only be serviced and repaired by trained electrotechnical personnel.

2.6.4 TRANSPORT

- Only transport the device in the original packaging.
- Protect the device against damage, caused, for instance, by jolts, knocks and contamination.

3. CONFIGURATION

3.1 ADJUST THE ADDRESS

For communication the Modbus RTU interface card needs an address. For this the same address is used, which is used also for communication over LWL and RS232. This can be adjusted with that LBA-2 and the Thyro-Tool Family.

Attention: The power controller must be switched off after a modification of the address of the Thyro-Tool Family, in order to activate the new address.

3.2 CONFIGURE THE TRANSFER PARAMETER

Over the DIP switch (see Figure 3.1) to be able the adjustments made, which are needed for the communication accommodation. In the standard adjustment all switches are open.



FIG. 3.1 CONFIGURATION SWITCH

In the following table the function of the switches is represented.

An open switch, and a 1 a closed switch represents 0.

SWITCH								FUNCTION
1	2	3	4	5	6	7	8	
0	0	0						4800 Baud
1	0	0						9600 Baud
0	1	0						19200 Baud
1	1	0						38400 Baud

0	0	1	57600 Baud
1	0	1	115200 Baud
0	1	1	230400 Baud
		1	Parity
		1	Even nOdd
		1	2 Stopp-Bit
		1	Long Break
		1	Mopo = Master

TAB. 3.1 ALLOCATION OF THE CONFIGURATION SWITCHES

Baud rate:

Over the first three switches the Baud rate can be selected.

The device supports from 4800 to 23400 Baud.

Factory setting = 4800 Baud.

Parity:

Over this switch the transfer with parity bit can be activated.

Factory setting = no parity.

Even nOdd:

With activated parity bit can be switched here between Even and Odd the parities.

Factory setting = Odd.

2 Stopp-Bit:

Over this switch an additional stop bit can be transmitted.

Factory setting = 1 stop bit.

Long Break:

With this switch the deceleration time can be increased between an inquiry of the masters and the response of the Slave around 3,5 byte.

Factory setting = no extension.

Mopo = Master:

This switch activates the additional writing „master desired value“ on the „Mopo desired value“ (see section 9).

Factory setting = deactivates.

4. INSTALLATION

After final configuration (chapter 3) can the modbus card plug into control section of the Thyro-P. In addition first control section is to be switched off. Now the card can into the extension slot be put and the cover plate be installed.

Subsequently, the card can be tested. There too the voltage supply of the control section is to be switched on. Subsequently, the status LED shows as entitled to the card on (see table 4.1). The status LED is between the plugs X20 and X21.

After switch on the control section should the LED with 1Hz flash. Subsequently, the bus can be attached. After accommodation to communication with the masters goes out the status LED.

STATE LED	MODBUS	MEANING
on	–	Card error
Flashing at 4 Hz	–	No communication with Thyro-P (SSC-Error)
Flashing at 1 Hz	off	No Bus-Signal
"	active	Card error
off	off	No connection with Thyro-P
"	active	OK

TAB. 4.1 STATE OF DIAGNOSTIC-LED

5. MODBUS-/J-BUS-COMMUNICATION

For the j-bus-telegram the move mode RTU (remote terminals unit) is used.

General structure of telegram:

START	ADDRESS	FUNCTION	DATA-BYTES	CRC	CRC
Time interval >3,5 Bytes	1 Byte	1 Byte	x Bytes	2 Bytes	Time interval 3,5 Bytes

The following functions are supported:

1. Read Holding Register
Reads in or several registers from the slave.
2. Preset Single Register
A register in the slave modifies.
3. Preset Multiple Regs
Several registers in the slave modify.
4. Report Slave ID
Reads the slave ID of the slaves.

A specification of the individual registers can be inferred from the section 10.

5.1 READ HOLDING REGISTERS (0X03)

With this telegram the master can pick one or more registers out from the Thyro-Tool Family (function code 0x03). Whereby the registers consecutively to be situated must.

Example:

From the controller with the address 100 registers 16 and 17 (power L1) are to be read.

Query:

ADDRESS	FUNCTION	REGISTER	COUNT	CRC
100	3	0, 16	0, 2	204, 59

Response:

ADDRESS	FUNCTION	COUNT BYTE	DATA	CRC
100	3	4	250, 184, 70, 23	13, 166

Error:

Is the address of the registers outside of the address area a exception Respons „ILLEGALY DATA ADDRESS“ (see paragraph 5.5) is transferred.

Query:

ADDRESS	FUNCTION	ERROR CODE	CRC
100	131	2	208, 238

Are More than 120 registers requested at the same time a exception Respons „ILLEGALY DATA VALUE“ (see section 5.5) is transferred.

Response:

ADDRESS	FUNCTION	ERROR CODE	CRC
100	131	3	17, 46

5.2 PRESET SINGLE REGISTER (0X06)

With this telegram the master can change a register in the Thyro-Tool Family (function code 0x06).

Example:

From the controller with the address 100 are to be changed register 96 (Betr) to 1 (Var).

Query:

ADDRESS	FUNCTION	REGISTER	DATA	CRC
100	6	0, 96	0, 1	65, 225

Response:

ADDRESS	FUNCTION	REGISTER	DATA	CRC
100	6	0, 96	0, 1	65, 225

Error:

If the address to write should register outside of the address area be appropriate or to be tried in an address, which cannot be changed, then as response the exception Respons is transferred „ILLEGALLY DATA ADDRESS“ (see section 5.5).

Response:

ADDRESS	FUNCTION	ERROR CODE	CRC
100	134	2	211, 190

5.3 PRESET MULTIPLE REGS (0X10)

With this telegram the master can change one or more registers in the Thyro-Tool Family (function code 0x10). Whereby the registers consecutively to be situated must.

Example:

From the controller with the address 100 register 145 and 146 (SST, SDN) to 5 (100ms) are to be changed.

Query:

ADDRESS	FUNCTION	REGISTER	COUNT	COUNT BYTE	DATA	CRC
100	16	0, 145	0, 2	4	0, 5, 0, 5	4, 192

Response:

ADDRESS	FUNCTION	REGISTER	COUNT	CRC
100	16	0, 145	0, 2	25, 208

Error:

Should the address registers outside of the address area a exception Respons „ILLEGALLY DATA ADDRESS“ (see section 5.5) is transferred.

Response:

ADDRESS	FUNCTION	ERROR CODE	CRC
100	144	2	221, 222

Should under the registers which be, only be selected can in such a way the desired modification ignored.

5.4 REPORT SLAVE ID (0X11)

With this telegram the master can select the slave ID (function code 0x01).

Example:

From the controller with the address 100 are to be selected the ID.

Query:

ADDRESS	FUNCTION	CRC
100	17	235, 124

Response:

ADDRESS	FUNCTION	COUNT BYTE	SLAVE ID	RUN STATE	CRC
100	17	2	4	255	18, 116

5.5 EXCEPTION RESPONSES

When incorrect inquiring an exception will transfer responses, and rejected the respective query.

ILLEGAL FUNCTION:

The function code received in the query is not an allowable action for the slave.

ILLEGAL DATA ADDRESS:

The registeraddress does not exist. It must be smaller than 624. With the inquiries „READ getting thing of register“ and „Preset multiple Regs“ consists the address of the start address of the register and number of registers. Thus applies: Register + number < 624.

ILLEGAL DATA VALUE:

The data in the inquiry are not permitted. For example the number of registers which can be read is too large (max 120).

6. FUNCTIONS

Via the register functions (addr. 624-628) can be executed in the con-troller determined functions (see table 6.1).

ADR	SYMBOL	VALUE	VALUE RANGE	COMBO-OPT	UNIT	R/W	DEFAULT
624		Acknowledge	0...1	OFF, QUIT		r/w	OFF
625		Reset	0...1	OFF, RESET		r/w	OFF
626		Save	0...1	OFF, SAVE		r/w	OFF
627		Regulator suppressor	0...1	OFF, ON		r/w	OFF
628		Ext. Error message	0...1	OFF, ON		r/w	OFF

TAB. 6.1 FUNCTIONS

Acknowledge:

Through set the register to 1 can a message be acknowledged. After execute the function the register is set to zero.

Reset:

Through set the register to 1 can that control section by the Thyro-Tool Family be reset. The bus card is not reset thereby. After execute the function the register is set to zero.

Save:

Through the register to 1 can all adjustments set be stored. The Thyro-Tool Family then always starts with the current adjustments. Also the automatic controller barrier is stored. After execute the function the register is set to zero.

Note: After transfer the instruction save may for 3 seconds no more parameters be modified.

Regulator suppressor:

Through set the register to 1 (regulator suppressor = ON) can the regulator suppressor be activated. Through they set are again deactivated to 0.

Ext. Error message:

Through set or reset this register can in the Thyro-Tool Family an external message be released. So that, via this function the relays or LEDs can be controlled (see Thyro-Tool Family manual).

7. STATUS MESSAGES

The status of the Thyro-Tool Family can be queried over the address 88. Each bit corresponds to a message, which displays the current status of the Thyro-Tool Family. An event pends, if the appropriate bit is set to 1. You receive details to the individual values in the guidance to the Thyro-Tool Family. The Table 7.1 illustrates the structure of the status messages.

BIT	STATE
15	MOSI in peak current limitation
14	SYNC fault
13	Overvoltage in mains
12	Undervoltage in mains
11	Overcurrent in load circuit
10	Undercurrent in load circuit
9	Regulator suppressor
8	Overtemperature
7	Limit
6	U limit
5	I limit
4	P limit
3	Pulse switch-off
2	Sensor breakage or short circuit
1	res.
0	SSC fault

TAB. 7.1 STATUS MESSAGES

On disturbances of communication between Modbus RTU interface card and Thyro-Tool Family, the „static diagnosis“ is released, and the message „SSC error“ transfer. It is then no data exchange between master and Slave possible. This error knows on the fact that e.g. the Modbus RTU interface card correctly does not sit in the module.

8. DIGITAL INPUTS

The Modbus RTU interface card provides three digital inputs as well as an input for the activation of the local operation (see section 9), via the 9-pin sub D plug (X21). They can be selected over the address 81.

PIN	DESIGNATION	FUNCTION
1	Earth	Earth
2	M1	Ground for IN0 and IN1
3	IN0	Input 0
4	IN1	Input 1
5	M24	Ground/internal 24 V supply
6	M2	Ground for IN2 and IN3
7	IN2	Input 2
8	Loc	Input 3
9	24	+24 V/internal 24 V supply

TAB. 8.1 CONNECTION ASSIGNMENT X21

Inputs 0 and 1 always relate to ground M1 and inputs 2 and Loc always relate to ground M2. There is also a 24 V supply provided for connecting simple signallers such as limit switches, etc. This would make the following connection possible, for example:

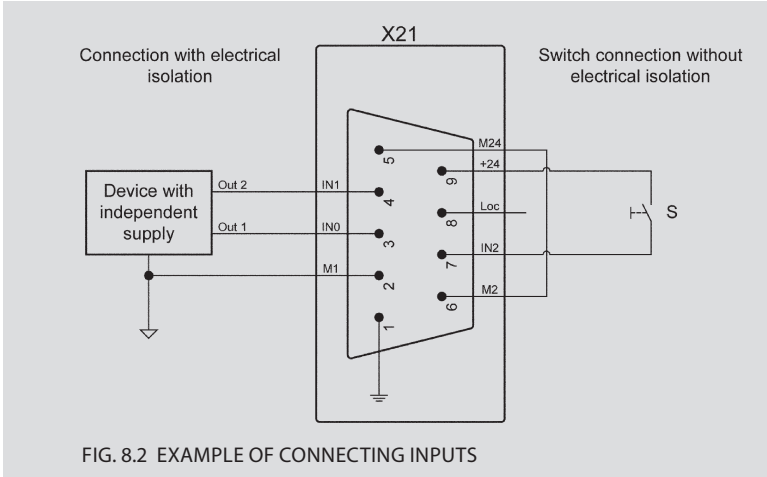

FIG. 8.2 EXAMPLE OF CONNECTING INPUTS

9. LOCAL OPERATION OF THE SETPOINT MOTORPOTI

In certain situations, e.g. failure of the modbus, it is sometimes necessary to change the desired value quickly. This can take place over the LBA-2. It is however pedantic for certain applications too. In order to remove this deficiency, the possibility of the local operation of the setpoint motorpoti was created over switches.

Over the input Loc (pin 8) can be activated the local operation of the setpoint motorpoti of desired value. It is then possible to switch the value SW_ACTIV between remote (open) and local (closed) over the input IN0 (pin 3).

In the local operation mode the setpoint motorpoti value can be changed over the inputs IN1 and IN2. Whereby the desired value with pressed switch around 1% per second changes. With simultaneous operation of the UP and Down keys the desired value is reduced.

For the local operation the plug X21 is to be connect as follows.

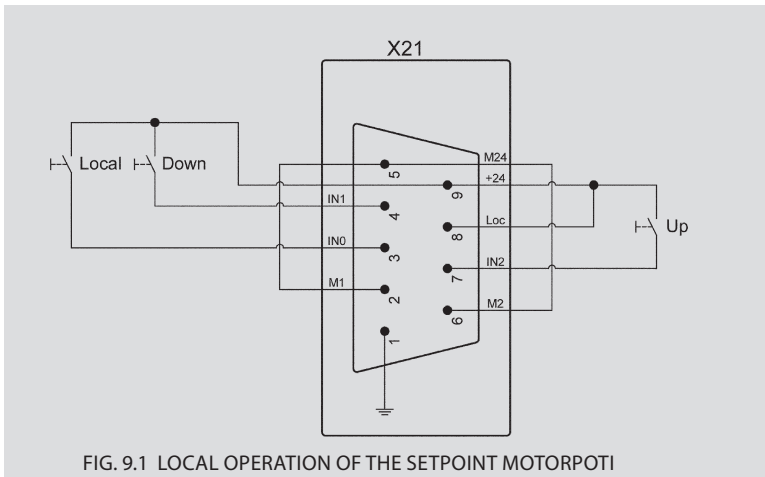

FIG. 9.1 LOCAL OPERATION OF THE SETPOINT MOTORPOTI

Note: When using the local operation the following points are to be considered:

1. To prevent a precipitous modification of the setpoint when switching from remote to local, the „setpoint motorpoti“ is set in the remote operation equal to the „setpoint master“. This takes place automatically by close switches no. 8 automatically (see section 3).

2. With the switch „local“ is closed („4 digital inputs“, bits 0 = 0) the process regulator must be deactivated and the „setpoint master“ is set equal to „setpoint total“, in order to enable a jumpfree switching from local to remote. For this the „setpoint total“ is to be transferred cyclically.
3. With switch from local to remote, the process regulator participates to initialize with the „setpoint total“ and has activate afterwards.

10. REGISTER

10.1 SETPOINTS

ADR	SETPOINTS	TYPE	SIZE	UNIT	R/W
0	Setpoint Master	integer	1	16383 == 100[%]	r/w
1	Setpoint Master Error	integer	1	16383 == 100[%]	r/w
2	Setpoint Motorpoti	integer	1	16383 == 100[%]	r/w
3	free		1		r
4	Setpoint Master	float	2	[W,V,A,%]	r/w
6	Setpoint Master Error	float	2	[W,V,A,%]	r/w
8	Setpoint Motorpoti	float	2	[W,V,A,%]	r/w
10	free	-	6	-	r

TAB. 10.1 REGISTER: SETPOINTS

„Setpoint Master“

With it the performance of the consumer can be controlled or regulated. The „Setpoint Master“ is constantly transferred to the Thyro-Tool Family so that no modification with LBA-2 etc. is possible.

„Setpoint Master Error“

This desired value is used in case of failure of the Modbus. The Modbus is failed if 1 second long no communication takes place.

Both being (master, master error) know either in % (integer) or absolute (float) to be indicated. The following is to be considered:

1. Both formats may be never changed at the same time, since the system is not to use white which it.
2. With specification of the being in absolute the log „Preset multiple Regs“ is to be used, since only so 2 words can be changed at the same time.
3. It is to be made certain that those are indicated absolutely values in the correct unit. This depends on the used type of regulation.

Note: If the controller is in remote operation („master desired value„is

active only), can it be meaningful, if the " master desired value " is written also on the " engine potentiometer desired value ". The to give when switching remote on restaurants no skip function on the automatic controller in the Thyro-Tool Family. This function can set through the second parameter in the Parametriertelegramm to 1 to be activated.

„Setpoint Motorpoti“

The „Setpoint Motorpoti“ can control Thyro-Tool Family like the „Setpoint Master“. It is transferred however to the Thyro-Tool Family only if the value over Modbus RTU were changed.

10.2 ACTUAL VALUES

ADR	ACTUAL VALUE	TYPE	SIZE	UNIT	R/W
16	Power L1	float	2	[W]	r
18	Voltage Load L1	float	2	[V]	r
20	Current L1	float	2	[A]	r
22	Load L1	float	2	[S]	r
24	Voltage Main L1	float	2	[V]	r
26	free	-	6	-	r
32	Power L2	float	2	[W]	r
34	Voltage Load L2	float	2	[V]	r
36	Current L2	float	2	[A]	r
38	Load L2	float	2	[S]	r
40	Voltage Main L2	float	2	[V]	r
42	free	-	6	-	r
48	Power L3	float	2	[W]	r
50	Voltage Load L3	float	2	[V]	r
52	Current L3	float	2	[A]	r
54	Load L3	float	2	[S]	r
56	Voltage Main L3	float	2	[V]	r
58	free	-	6	-	r
64	Total power	float	2	[W]	r
66	Temperature	float	2	[°C]	r
68	Total setpoint	float	2	[W,V,A,%]	r
70	Setpoint Mopo	float	2	[W,V,A,%]	r
72	Total setpoint	integer	1	16383 == 100[%]	r
73	Setpoint Mopo	integer	1	16383 == 100[%]	r
74	Setpoint terminal 10	integer	1	16383 == 100[%]	r
75	Setpoint terminal 11	integer	1	16383 == 100[%]	r
76	Setpoint active	integer	1	-	r
77	On-angle alpha	integer	1	18000 == 180°el	r
78	On-time value	integer	1	[periods]	r
79	Period	integer	1	[µs]	r
80	LED & Relais state	integer	1	-	r
81	Digital inputs	integer	1	4 Bit	r
82	Operating hours	float	2	[h]	r
88	State	integer	1	-	r
89	Energy	float	2	[kWh]	r

TAB. 10.2 REGISTER: ACTUAL VALUES

10.3 PARAMETERS

ADR	SYMBOL	VALUE	VALUE RANGE	COMBO-OPT	UNIT	R/W	DEFAULT
96	BETR	Operating mode	0..2	TAKT, VAR, SSSD		r/w	TAKT
97	MOSI	Op. of molybdenum silicide rods	0..2	OFF, RAMP, STELL		r/w	OFF
98	SEB	Service mode	0..1	OFF, ON		r/w	OFF
99	ASM	Automatic synchronisation for multiple power controller applications	0..1	OFF, ON		r	OFF
100	ASM_SUMM	ASM total current	1..65535		[A]	r/w	65000
101	TYP	Number of controlled phases	1..3			r/w	1 phase
102	NLT	Directly earthed conductor	0..1	OFF, ON		r/w	OFF
103	NACHIMP	Re-ignitions	0..1	OFF, ON		r/w	
104	SCHW	Phase shift	0..1	OFF, ON		r/w	
105	SCHW_POL	Phase shift polarity	0..1	plus, minus		r/w	plus
106	SCHW_L1	Phase shift L1	0..360°el		0,01 °el	r/w	0
107	SCHW_L2	Phase shift L2	0..360°el		0,01 °el	r/w	0
108	SCHW_L3	Phase shift L3	0..360°el		0,01 °el	r/w	0
109	SYNC_ANZ	Number of sync voltages	1..3			r/w	
110	SYNC_DREHF	Rotating field	0..1	right, left		r/w	right
111	KANALTREN	Canal-separation	0..1	OFF, ON		r/w	ON

TAB. 10.3 REGISTER: OPERATING MODE

ADR	SYMBOL	VALUE	VALUE RANGE	COMBO-OPT	UNIT	R/W	DEFAULT
144	AN1	Phase angle of the 1st half-wave	0..180°el		0,01 °el	r/w	60°el
145	SST	Soft-start time (setting)	0..9980 ms		20 ms	r/w	120 ms
146	SDN	Soft-down time (setting)	0..9980 ms		20 ms	r/w	120 ms
147	T ₀	Cycle period	0..T ₀ _MAX		20 ms	r/w	1 s
148	T ₀ _MAX	Max. cycle period	02...1310s		20 ms	r/w	5 s
149	TSMAX	Maximum cycle on-time	0..T ₀		20 ms	r/w	1 s
150	TSMIN	Minimum cycle on-time	0..T ₀		20 ms	r/w	0 ms
151	MP	Min. pause	0..200ms		20 ms	r/w	
152	SYNC_EXT	Synchronous cycle internal/external	0..1	internal, external		r	internal
153	SYNC_ADR	Synchronous cycle address	0..655350 ms		10 ms	r/w	1 ms

TAB. 10.4 REGISTER: TIMES

ADR	SYMBOL	VALUE	VALUE RANGE	COMBO-OPT	UNIT	R/W	DEFAULT
192	RE	Regulation	0..8	Uload ² , Uload eff, lload ² , lload eff, Real power, res, res, res, without regulation		r/w	Uload ²
193	STD_RE	Standard regulator	0..1	OFF, ON		r/w	ON
194	TI_1	PID-regulator, I-part 0 = off	0..65535			r/w	800
195	KP_1	PID-regulator, P-part 0 = off	0..65535			r/w	160
196	KR_1	PID-regulator, counter P-part	0..65535			r/w	1
197	TD_1	PID-regulator, D-part 0 = off	0..65535			r/w	0
198	TI_1_STD	PID-regulator, I-part, default value	0 = off 0..65535			r	800
199	KP_1_STD	PID-regulator, P-part, default value	0 = off 0..65535			r	160
200	KR_1_STD	PID-regulator, counter P-part, default value	0..65535			r	1
201	TD_1_STD	PID-regulator, D-part, default value	0 = off 0..65535			r	0
202	MOSI_WL_GE_1	Rate of angular displacement 1	0..65535			r/w	1100
203	MOSI_WL_GE_2	Rate of angular displacement 2	0..65535			r/w	50

TAB. 10.5 REGISTER: CONTROLS

ADR	SYMBOL	VALUE	VALUE RANGE	COMBO-OPT	UNIT	R/W	DEFAULT
240	UEMI	Minimum r.m.s. voltage setpoint	0..65535 V		V	r/w	0V
241	UEMA	Maximum r.m.s. voltage setpoint	0..65535 V		V	r/w	440V
242	IEMI	Minimum r.m.s. current setpoint	0..65535 A		A	r/w	0A
243	IEMA	Maximum r.m.s. current setpoint	0..65535 A		A	r/w	110 A
244	PMI_H	Minimum power setpoint hi	0..65535 xW		65536 W	r/w	0W
245	PMI_L	Minimum power setpoint low	0..65535 W		W	r/w	0W
246	PMA_H	Maximum power setpoint hi	0..65535 xW		65536 W	r/w	0W
247	PMA_L	Maximum power setpoint low	0..65535 W		W	r/w	48400 W
248	V_IE	Front pulse limit position	0..180°el		0.01°el	r/w	180°el
249	H_IE	Back pulse limit position	0..180°el		0.01°el	r/w	0°el

TAB. 10.6 REGISTER: LIMIT

ADR	SYMBOL	VALUE	VALUE RANGE	COMBO-OPT	UNIT	R/W	DEFAULT
288	SW_ACTIV	Setpoint activation	0..15	0 = 1 (Setpoint t10 active) ...		r/w	15
289	SW	Setpoint linking	0..3	_ADD, IADD, _PRO, IPRO		r/w	_ADD
290	MOSI_IS_FA	Factor peak current limitation	0..1000			r/w	25
291	SW_SPRUNG	Setpoint jump correction	0..1	OFF, ON		r/w	ON
292	SW_INP_IU_10	Input voltage/current terminal 10	0..2	5V, 10V, 20 mA		r/w	20 mA
293	STA_REGLER	Control start regulator input terminal 10	depends on SW_INP_IU_10		0,3 mV 0,6 mV 1,22 uA	r/w	292 uA (240)
294	STE_REGLER	Control end regulator input terminal 10	depends on SW_INP_IU_10		0,3 mV 0,6 mV 1,22 uA	r/w	20 mA (16383)
295	SW_INP_IU_11	Input voltage/current terminal 11	0..2	5V, 10V, 20 mA		r/w	5 V
296	STA_POTI	Control start regulator input terminal 11	depends on SW_INP_IU_11		0,3 mV 0,6 mV 1,22 uA	r/w	72 mV (240)
297	STE_POTI	Control end regulator input terminal 11	depends on SW_INP_IU_11		0,3 mV 0,6 mV 1,22 uA	r/w	5 V (16383)
298	STA_MASTER	Control start master	0..100%		0,0061%	r/w	0%
299	STE_MASTER	Control end master	0..100%		0,0061%	r/w	100% (16383)
300	STA_MOPO	Control start motor potentiometer	0..100%		0,0061%	r/w	0%
301	STE_MOPO	Control end motor potentiometer	0..100%		0,0061%	r/w	100% (16383)

TAB. 10.7 REGISTER: CONTROL CHARACTERISTIC

ADR	SYMBOL	VALUE	VALUE RANGE	COMBO-OPT	UNIT	R/W	DEFAULT
336	TEMP	Temperature sensor	0..3	none, Pt100, PT1000, NTC		r/w	none
337	TEMP_KVE	Characteristic number	0..7	Characteristic 0 ... Characteristic 7		r/w	
338	FU_DR_BR	Level wire breakage	0..4000		Ohm	r/w	
339	FU_KURZ	Level short circuit	0..4000		Ohm	r/w	
340	TEMP_FE_DAU	Temperature error duration	1..1000		20 ms	r/w	200 ms (10)

TAB. 10.8 REGISTER: TEMPERATURE

ADR	SYMBOL	VALUE	VALUE RANGE	COMBO-OPT	UNIT	R/W	DEFAULT
384	MITTEL	Averaging	0..1000			r/w	25
385	IST_1	Actual value output 1	0..1	20 mA, 10 V		r/w	20 mA
386	OF_1	Offset 1	0..20000 uA		uA	r/w	0 uA
387	DAC1_VA_U	Measuring instrument full-scale deflection DAC1, voltage	0..10000 mV		mV	r/w	10 V
388	DAC1_VA_I	Measuring instrument full-scale deflection DAC1, current	0..20000 uA		uA	r/w	20 mA
389	DAC_1_CTRL	Configuration register analog output 1	bitwise			r/w	18
390	U_FA_1	Scale end value voltage actual value output 1	0..65535 A		A	r/w	150 A
391	I_FA_1	Scale end value current actual value output 1	0..65535 V		V	r/w	500 V
392	P_FA_1_H	Scale end value power actual value output 1	0..65535 xW		xW	r/w	0 W
393	P_FA_1_L	Scale end value power actual value output 1	0..65535 W		W	r/w	50000 W
394	ALPHA_FA_1	Scale end value alpha actual value output 1	0..180°el		,01°el	r/w	180°el
395	IST_2	Actual value output 2	0..1	20 mA, 10 V		r/w	20 mA
396	OF_2	Offset 2	0..20000 uA		uA	r/w	0 uA
397	DAC2_VA_U	Measuring instrument full-scale deflection DAC2, voltage	0..10000 mV		mV	r/w	10 V
398	DAC2_VA_I	Measuring instrument full-scale deflection DAC2, current	0..20000 uA		uA	r/w	20 mA
399	DAC_2_CTRL	Configuration register analog output 2	bitwise			r/w	18
400	U_FA_2	Scale end value voltage actual value output 2	0..65535 A		A	r/w	150 A
401	I_FA_2	Scale end value current actual value output 2	0..65535 V		V	r/w	500 V
402	P_FA_2_H	Scale end value power actual value output 2	0..65535 xW		xW	r/w	0 W
403	P_FA_2_L	Scale end value power actual value output 2	0..65535 W		W	r/w	50000 W
404	ALPHA_FA_2	Scale end value alpha actual value output 2	0..180°el		,01°el	r/w	180°el
405	IST_3	Actual value output 3	0..1	20 mA, 10 V		r/w	20 mA
406	OF_3	Offset 3	0..20000 uA		uA	r/w	0 uA
407	DAC3_VA_U	Measuring instrument full-scale deflection DAC3, voltage	0..10000 mV		mV	r/w	10 V
408	DAC3_VA_I	Measuring instrument full-scale deflection DAC3, current	0..20000 uA		uA	r/w	20 mA
409	DAC_3_CTRL	Configuration register analog output 3	bitwise			r/w	18
410	U_FA_3	Scale end value voltage actual value output 3	0..65535 A		A	r/w	150 A
411	I_FA_3	Scale end value current actual value output 3	0..65535 V		V	r/w	500 V
412	P_FA_3_H	Scale end value power actual value output 3	0..65535 xW		xW	r/w	0 W
413	P_FA_3_L	Scale end value power actual value output 3	0..65535 W		W	r/w	50000 W
414	ALPHA_FA_3	Scale end value alpha actual value output 3	0..180°el		,01°el	r/w	180°el

TAB. 10.9 REGISTER: ANALOG OUTPUTS

ADR	SYMBOL	VALUE	VALUE RANGE	COMBO-OPT	UNIT	R/W	DEFAULT
432	I_TYP	Power controller rated current	0..65535A		A	r/w	110 A
433	I_TYP_LSB	Rated current in LSB	0..65535			r	
434	UE_I	Voltage converter ratio	0..65535			r/w	100
435	R_BUERDE_I	Load resistor current	0..653 Ohm		,01Ohm	r/w	0.91 Ohm
436	NORM_I	Scaling factor current	0..65535			r/w	
437	I_SCHW	Current value threshold	0..65535		0,1A	r/w	6500 A
438	U_TYP	Power controller connection voltage	0..1000V		V	r/w	400 V
439	U_TYP_LSB	Rated voltage in LSB	0..65535			r	
440	U_NETZ_ANW	Mains voltage user	0..1000V		V	r/w	400 V
441	UE_U	Voltage converter ratio	0..1000			r/w	16
442	TYP_BEREICH	Voltage range changeover	0..2	230V, 400V, 690V		r/w	400 V
443	R_BUERDE_U	Load resistor voltage	0..65535 Ohm		Ohm	r/w	1680 Ohm
444	R_BUERDE_U_1	Load resistor voltage range 1	0..65535 Ohm		Ohm	r/w	1680 Ohm
445	R_BUERDE_U_2	Load resistor voltage range 2	0..65535 Ohm		Ohm	r/w	1680 Ohm
446	U_NORM_230	Scaling factor 230V	0..65535			r/w	
447	U_NORM_400	Scaling factor 400V	0..65535			r/w	
448	U_NORM_690	Scaling factor 500V-690V	0..65535			r/w	
449	FREQ_MIN	Min. frequency	14286..25000, 1/X * 10^6		Hz	r/w	22222 (45 Hz)
450	FREQ_MAX	Max. frequency	14286..25000, 1/X * 10^6		Hz	r/w	15151 (66 Hz)
451	FREQ_TOL	Frequency tolerance	0..100		%	r/w	10%
452	P_TYP_H	Power controller rated power hi	0..65535 xW		xW	r/w	0 W
453	P_TYP_L	Power controller rated power low	0..65535 W		W	r/w	44000 W
454	P_TYP_LSB_H	Rated power hi in LSB	0..65535 x			r	
455	P_TYP_LSB_L	Rated power low in LSB	0..65535			r	
456	TI_FA	Potentiometer regulator parameter Ti	0..65535			r/w	0
457	KP_FA	Potentiometer regulator parameter Kp	0..65535			r/w	0
458	R_TEIL	Voltag divider resistor	0..65535		Ohm	r/w	36000
459	MESS	Meter circuit	0..5	Aron, 1/2 Aron 1, 1/2 Aron 2, 1/2 Aron 3, asymmetrical load, symmetrical load		r/w	

TAB. 10.10 REGISTER: HARDWARE PARAMETER

ADR	SYMBOL	VALUE	VALUE RANGE	COMBO-OPT	UNIT	R/W	DEFAULT
480	SPG_MIN	Mains voltage monitoring minimum	0...1000 V		V	r/w	
481	SPG_MAX	Mains voltage monitoring maximum	0...1000 V		V	r/w	
482	UN_S	Undercurrent monitoring	0..1	OFF, ON		r/w	OFF
483	UE_S	Overcurrent monitoring	0..1	OFF, ON		r/w	OFF
484	REL_ABS	Load break	0..1	REL_, ABS		r/w	REL_
485	LASTBRUCH_M IN	Undercurrent monitoring value	0..99%		%	r/w	0%
486	LASTBRUCH_M AX	Overcurrent monitoring value	101...255%		%	r/w	0%
487	LASTBRUCH_M IN_ABS	Undercurrent monitoring value	0..65535			r/w	0
488	LASTBRUCH_M AX_ABS	Overcurrent monitoring value	0..65535			r/w	0
489	L2_ENA	Monitoring L2 enable	0..1	OFF, ON		r/w	OFF
490	L3_ENA	Monitoring L3 enable	0..1	OFF, ON		r/w	OFF

TAB. 10.11 REGISTER: MONITORING

ADR	SYMBOL	VALUE	VALUE RANGE	COMBO-OPT	UNIT	R/W	DEFAULT
528	K1RU	LED&Relays work principle	0..256, bitwise	Open-circuit principle Closed-circuit principle		r/w	
529	OUT0_CFG	LED CONTROL mode	0..65535			r/w	
530	OUT1_CFG	LED LIMIT mode	0..65535			r/w	
531	OUT2_CFG	LED PULSE LOCK mode	0..65535			r/w	
532	OUT3_CFG	LED FAULT mode	0..65535			r/w	
533	OUT4_CFG	LED OVERHEAT mode	0..65535			r/w	
534	OUT5_CFG	Relay K1 mode	0..65535			r/w	
535	OUT6_CFG	Relay K2 mode	0..65535			r/w	
536	OUT7_CFG	Relay K3 mode	0..65535			r/w	
537	OUT0_ STOERM_L	LED CONTROL config 0	0..65535			r/w	
538	OUT1_ STOERM_L	LED LIMIT config 0	0..65535			r/w	
539	OUT2_ STOERM_L	LED PULSE LOCK config 0	0..65535			r/w	
540	OUT3_ STOERM_L	LED FAULT config 0	0..65535			r/w	
541	OUT4_ STOERM_L	LED OVERHEAT config 0	0..65535			r/w	
542	OUT50_ STOERM_L	Relay K1 config 0	0..65535			r/w	
543	OUT6_ STOERM_L	Relay K2 config 0	0..65535			r/w	
544	OUT7_ STOERM_L	Relay K3 config 0	0..65535			r/w	
545	OUT0_ STOERM_H	LED CONTROL config 1	0..65535			r/w	
546	OUT1_ STOERM_H	LED LIMIT config 1	0..65535			r/w	
547	OUT2_ STOERM_H	LED PULSE LOCK config 1	0..65535			r/w	
548	OUT3_ STOERM_H	LED FAULT config 1	0..65535			r/w	
549	OUT4_ STOERM_H	LED OVERHEAT config 1	0..65535			r/w	
550	OUT50_ STOERM_H	Relay K1 config 1	0..65535			r/w	
551	OUT6_ STOERM_H	Relay K2 config 1	0..65535			r/w	
552	OUT7_ STOERM_H	Relay K3 config 1	0..65535			r/w	

TAB. 10.12 REGISTER: LED & RELAYS

ADR	SYMBOL	VALUE	VALUE RANGE	COMBO-OPT	UNIT	R/W	DEFAULT
576	DA_EN_2	Data logger register hi	0..65535			r/w	
577	DA_EN_1	Data logger register low	0..65535			r/w	
578	RESET_2	Reset trigger on error register hi	0..65535			r/w	
579	RESET_1	Reset trigger on error register low	0..65535			r/w	
580	IMAB_2	Pulse switch-off on error register hi	0..65535			r/w	
581	IMAB_1	Pulse switch-off on error register low	0..65535			r/w	
582	VERS_J	Version year	0..9999			r	
583	VERS_M	Version month	1..12			r	
584	VERS_T	Version day	1..31			r	
585		Modbus version year	0..9999			r	
586		Modbus version month	1..12			r	
587		Modbus version day	1..31			r	
588	USER_PARA_0	Userparameter 0	0..65535			r/w	
589	USER_PARA_1	Userparameter 1	0..65535			r/w	
590	USER_PARA_2	Userparameter 2	0..65535			r/w	
591	USER_PARA_3	Userparameter 3	0..65535			r/w	
592	USER_PARA_4	Userparameter 4	0..65535			r/w	
593	USER_PARA_5	Userparameter 5	0..65535			r/w	
594	USER_PARA_6	Userparameter 6	0..65535			r/w	
595	USER_PARA_7	Userparameter 7	0..65535			r/w	
596	USER_PARA_8	Userparameter 8	0..65535			r/w	
597	USER_PARA_9	Userparameter 9	0..65535			r/w	
598	USER_PARA_10	Userparameter 10	0..65535			r/w	
599	USER_PARA_11	Userparameter 11	0..65535			r/w	
600	USER_PARA_12	Userparameter 12	0..65535			r/w	
601	USER_PARA_13	Userparameter 13	0..65535			r/w	
602	USER_PARA_14	Userparameter 14	0..65535			r/w	

TAB. 10.13 REGISTER: MISCELLANEOUS

ADR	SYMBOL	VALUE	VALUE RANGE	COMBO-OPT	UNIT	R/W	DEFAULT
624		Acknowledge	0..1	OFF, QUIT		r/w	OFF
625		Reset	0..1	OFF, RESET		r/w	OFF
626		Save	0..1	OFF, SAVE		r/w	OFF
627		Regulator suppressor	0..1	OFF, ON		r/w	OFF
628		Ext. Error message	0..1	OFF, ON		r/w	OFF

TAB. 10.14 REGISTER: FUNCTIONS



World Headquarters
1625 Sharp Point Drive
Fort Collins, CO 80525 USA

970.221.4670 Main
970.221.5583 Fax

www.advanced-energy.com

Specifications are subject to change without notice.

© 2014 Advanced Energy Industries, Inc. All rights reserved. Advanced Energy® and Thyro-P™ are trademarks of Advanced Energy Industries, Inc.

