

## Power Standard Model 2602A

Instruction and Service Manual  
PN# 2602A-900  
Publication Date: January, 2018  
REV. B



TEGAM is a manufacturer of electronic test and measurement equipment for metrology, calibration, and production test. We also provide repair, calibration, and other support services for a wide variety of test and measurement equipment including RF power sensor calibration systems, RF attenuation measurement systems, ratio transformers, arbitrary waveform generators, micro-ohmmeters, LCR meters, handheld temperature calibrators, thermometers, humidity and temperature control devices, and more.

TEGAM also repairs and calibrates test and measurement equipment formerly manufactured by Electro-Scientific Industries (ESI), Gertsch, Keithley Instruments, Lucas Weinschel, and Pragmatic Instruments. A complete list can be viewed on our Product Service Directory at [www.tegam.com](http://www.tegam.com)

For more information about TEGAM and our products, please visit our website at [www.tegam.com](http://www.tegam.com): or contact one of our customer service representatives at [sales@tegam.com](mailto:sales@tegam.com) or 800-666-1010.



10 Tegam Way,  
Geneva, Ohio 44041

Telephone: (440) 466-6100  
Fax: (440) 466-6110  
E-mail: [sales@tegam.com](mailto:sales@tegam.com)

## Table of Contents

Section	Page
<b>I. Introduction</b>	
Purpose and functions.....	1-1
Capabilities.....	1-1
Performance characteristics.....	1-2
Environmental information.....	1-2
Preparation for calibration or repair and shipping.....	1-3
Expedite Repair Form.....	1-4
Warranty information.....	1-4
TEGAM contact information.....	1-5
<b>II. Preparation for Use and Installation</b>	
Unpacking & Inspection.....	2-1
Recommended Operating Environment.....	2-1
<b>III. Principles of Operation</b>	
Power Measurements.....	3-1
Principles of DC Substitution.....	3-1
Temperature Variable Resistance.....	3-1
Power Splitters.....	3-1
Controlling Thermistor Temperature.....	3-2
<b>IV. Operating Instructions</b>	
Front Panel Connectors.....	4-1
Calculating Calibration Factors.....	4-3
Relationship between k, gamma. And effective efficiency.....	4-7
<b>V. Maintenance and Servicing</b>	
Maintenance.....	5-1
Care and Handling of Assemblies.....	5-1
Connector Torque.....	5-2
Connector Care and Cleaning.....	5-3
<b>VI. Preparation for Shipment</b>	
Returning power standard for service.....	7-1
Repacking for shipment.....	7-1
<b>VII. Storage</b>	
Temperature and other environmental limitations.....	8-1

**Safety Information & Precautions:**

The following safety information applies to both operation and service personnel. Safety precautions and warnings may be found throughout this instruction manual and the equipment. These warnings may be in the form of a symbol or a written statement. Below is a summary of these precautions.

**Terms in This Manual:**

CAUTION statements identify conditions or practices that could result in damage to the equipment or other property.

WARNING statements identify conditions or practices that could result in personal injury or loss of life.

**Terms as Marked on Equipment:**

CAUTION indicates a personal injury hazard not immediately accessible as one reads the marking, or a hazard to property including the equipment itself.

DANGER indicates a personal injury hazard immediately accessible as one reads the marking.

Symbols:

*As Marked in This Manual:*

	This symbol denotes where precautionary information may be found.
--	---

*As Marked on Equipment:*

	CAUTION – Risk of Danger
	DANGER – Risk of Electric Shock
	Earth Ground Terminal
I	On
O	Off
	Frame or Chassis Terminal
	Earth Ground Terminal
	Alternating Current

## Purpose and Function

This Coaxial RF Power Standard is designed for the precise measurement of microwave power up to 250 W in the 1000 MHz to 3000 MHz frequency range. This standard is configured as a feedthrough standard. The feedthrough standard is constructed of a directional coupler paired with a 1505A thermistor power standard. The design has the coupler and 1505A mounted on an aluminum heat sink to reduce changes in coupling factor attributable to heating. These standards are highly accurate and stable with time and temperature. They are ideal for use as standards for the transfer of calibration factors to other high power RF standards and power sensors.

## Capabilities

This Coaxial RF Power Standard is designed for the calibration laboratory. These units are highly accurate, stable with time and temperature, and are designed for use as a standard for the characterization of calibration factors for other sensors.

**Table 1.1 General Specifications**

<b>Frequency Range</b>	700 MHz to 3500 MHz
<b>Connector Type</b>	N
<b>Max Power</b>	+54 dBm, 250 W
<b>RF Impedance</b>	50 Ohms nominal
<b>Power Linearity</b>	<0.25% from +44 to +54 dBm (25 to 250 W)
<b>Typical Usable Range</b>	+34 to +54 dBm (2.5 to 250 W) (Depends on noise floor and resolution of DC instruments)
<b>Calibration Factor Drift</b>	<0.5% per year
<b>Individual Calibration factors are supplied standard at the following frequencies. Inquire about additional points.</b>	700 to 2400 MHz in 100 MHz steps, 2450 MHz 2500 MHz to 3500 MHz in 100 MHz steps
<b>2-Sigma Calibration Factor Uncertainty</b>	±1%
<b>Cal Factor Temperature Coefficient</b>	< 18 °C or > 24 °C, add 0.6% / °C
<b>Thermistor DC Bias Power</b>	Approximately 30 to 80 mW (nominal)
<b>Thermistor Resistance at Bias</b>	200 Ohms (set by balancer)
<b>Max VSWR</b>	1.2 : 1
<b>Typical Insertion Loss</b>	0.5 dB
<b>Nominal Coupling Factor</b>	43 dB
<b>Temperature:</b>	<b>Operating</b> +15° to +30° C (+59° to +86° F)
	<b>Storage</b> -55° to +75° C (-67° to +167° F)
<b>Physical Dimensions:</b>	<b>Height</b> 176 mm (6.93 in)
	<b>Width</b> 266 mm (10.47 in)
	<b>Depth</b> 128 mm (5.04 in)
<b>Weight</b>	5 kg (11 lbs)

## Preparation For Calibration Or Repair Service

Once you have verified that the cause for the Coaxial RF Power Standards malfunction cannot be solved in the field and the need for repair and calibration service arises, contact TEGAM customer service to obtain an RMA, (Returned Material Authorization), number. You can contact TEGAM customer service via the TEGAM website, [www.tegam.com](http://www.tegam.com) or by calling 440.466.6100 (*All Locations*) OR 800.666.1010 (*United States Only*).

The RMA number is unique to your instrument and will help us identify you instrument and to address the particular service request by you which is assigned to that RMA number.

Of even importance, a detailed written description of the problem should be attached to the instrument. Many times repair turnaround is unnecessarily delayed due to a lack of repair instructions or of a detailed description of the problem.

This description should include information such as measurement range, and other instrument settings, type of components being tested, are the symptoms intermittent, conditions that may cause the symptoms, has anything changed since the last time the instrument was used, etc. Any detailed information provided to our technicians will assist them in identifying and correcting the problem in the quickest possible manner. Use a copy of the Repair and Calibration Service form provided on the next page.

Once this information is prepared and sent with the instrument to our service department, we will do our part in making sure that you receive the best possible customer service and turnaround time possible.



## Warranty

TEGAM, Inc. warrants this product to be free from defects in material and workmanship for a period of one (1) year from the date of shipment. During this warranty period, if a product proves to be defective, TEGAM Inc., at its option, will either repair the defective product without charge for parts and labor, or exchange any product that proves to be defective.

TEGAM, Inc. warrants the calibration of this product for a period of one (1) year from date of shipment. During this period, TEGAM, Inc. will recalibrate any product which does not conform to the published accuracy specifications.

In order to exercise this warranty, TEGAM, Inc., must be notified of the defective product before the expiration of the warranty period. The customer shall be responsible for packaging and shipping the product to the designated TEGAM service center with shipping charges prepaid. TEGAM Inc. shall pay for the return of the product to the customer if the shipment is to a location within the country in which the TEGAM service center is located. The customer shall be responsible for paying all shipping, duties, taxes, and additional costs if the product is transported to any other locations. Repaired products are warranted for the remaining balance of the original warranty, or 90 days, whichever period is longer.

## Warranty Limitations

The TEGAM, Inc. warranty does not apply to defects resulting from unauthorized modification or misuse of the product or any part. This warranty does not extend to connector wear and tear, damage, or corrosion. This warranty does not apply to fuses, batteries, or damage to the instrument caused by battery leakage.

## Statement of Calibration

This instrument has been inspected and tested in accordance with specifications published by TEGAM Inc. The calibration of this instrument is traceable to the International System of Units (SI) through the National Institute of Standards and Technology (NIST) or other recognized National Metrology Institutes, by comparison to equipment and standards maintained in the laboratories of TEGAM Inc.

Document publishing dates may lag product changes.  
Visit [www.tegam.com](http://www.tegam.com) to download the latest version of this manual.

### Contact Information:

TEGAM INC.  
10 TEGAM WAY  
GENEVA, OHIO 44041  
PH: 440.466.6100  
FX: 440.466.6110  
EMAIL: [sales@tegam.com](mailto:sales@tegam.com)  
WEB: <http://www.tegam.com>





## Unpacking & Inspection

Each Coaxial RF Power Standards is put through a series of electrical and mechanical inspections before shipment to the customer. Upon receipt of your instrument unpack all of the items from the shipping carton and inspect for any damage that may have occurred during transit. Report any damaged items to the shipping agent. Retain and use the original packing material for reshipment if necessary.

Upon Receipt, inspect the carton for the following items:

**Table 2.1 Packing List**

Item	Part Number
Model 2602A Coaxial RF Power Standard	2602A
Technical (Operation and Maintenance) Manual	2602A-900
Calibration Certificate with Data	N/A

## Mounting

The Model 2602A is not designed to be rack mounted.

### Only use with Proper Equipment:

The 2602A is designed to be used with the TEGAM Model 1830A with bias and heater cable CA-21-15 or CA-21-48.

## Use in Proper Environment

Normal calibration laboratory practice dictates that the environment should be closely controlled. This will minimize errors introduced by temperature and humidity changes. A nominal temperature of +23°C (+73.4°F) provides a good working condition. A tolerance of  $\pm 1^\circ\text{C}$  gives an ideal temperature spread. Controlled temperatures also stabilize the aging process of the standards.

**CAUTION:** The RF Power Standards have a specified operating temperature range of +15° to +30° C (+59° to +86° F). Operating beyond these limits can damage internal circuitry. Operating the instrument beyond the temperatures specified in Table 1.1 can affect the accuracy of the instrument. See *Table 1.1, Temperature Coefficient*.

**CAUTION:** When an RF Power Standard is to be stored for extended periods, pack the instrument into a container. Place container in a clean, dry, temperature-controlled location. If instrument is to be stored in excess of 90 days, place desiccant with items before sealing container. The safe environmental limits for storage are -55° to +75° C (-67° to +167° F) at less than 95% non-condensing relative humidity.

**Do Not Use in Explosive Environments**

CAUTION: The 2602A is not designed for operation in explosive environments.

**Do Not Operate Without Covers**

WARNING: This device should be operated with all panels and covers in place. Operation with missing panels or covers could result in personal injury.

## Theory of RF Measurements with the 2602A

### Power Measurements

RF power is measured in terms of a power change across the precision resistance leg of a TEGAM 1830A Bridge Circuit. A digital voltmeter measures voltage across the precision resistance leg which can be used to determine the power.

The total power applied to the thermistor leg (in the RF Power Standard) of the Type IV Bridge equals the sum of both DC *and* RF power. The precision resistor leg only has DC power applied to it. Thus, the RF power introduced to the thermistor is directly proportional to the change in DC power across the precision resistor.

### Principle of DC Substitution

The RF Power Standards use the principle of DC substitution to measure RF power. DC substitution refers to the measurement of RF power according to the amount of DC power that must be substituted for the RF power in a bolometer in order to cause equivalent thermal effects. Since some of the RF power applied to the input of the power standard is lost by reflection and other causes before it is applied to the thermistor element, a calibration factor for the standard is to determine the actual level of RF power. TEGAM Coaxial RF Power Standards are configured to provide a path for RF energy via a coaxial line. DC Bias is introduced from the Bias terminals to the thermistors.

### Temperature Variable Resistance

Each RF Standard contains a pair of thermistor beads whereby the resistance changes as a function of temperature. Thermistor bead temperature is a function of the combined DC and RF power applied to the beads and the ambient temperature surrounding the beads. The level of power applied to the beads is controlled externally. A heating element, controlled by an external controller, provides ambient temperature stability.

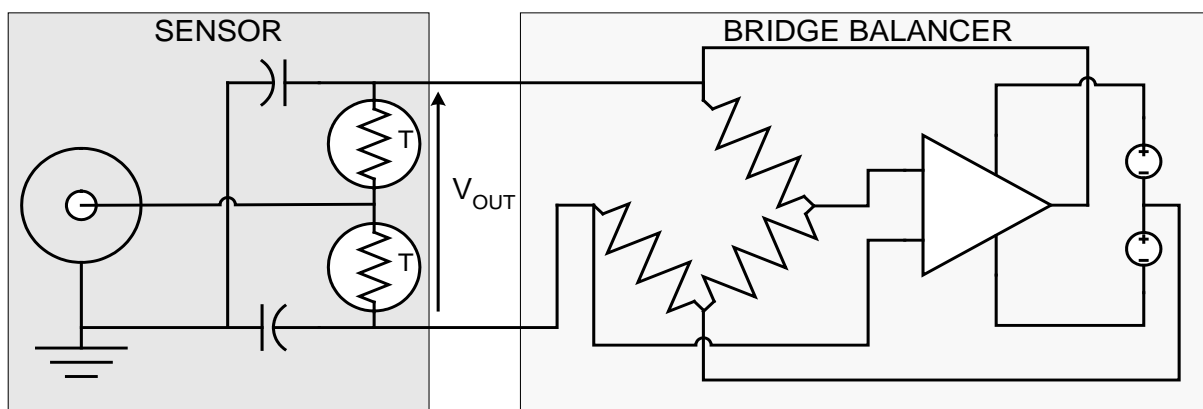

**Figure 3.1 Thermistor and Bridge Balancer**

Figure 3.1 depicts the thermistor assembly electrical configuration. DC biasing of the dual thermistor beads to 100 ohms each provides a nominal 50 ohm parallel RF resistance and a 200 ohm series DC resistance. A DC blocking capacitor and bypass capacitors isolate DC from RF signals. Filtering capacitors provide low VSWR in the lower end of the frequency range. Application of approximately 35 mW of power to the thermistor beads produces a 200 ohm DC resistance. As the power applied to the thermistor beads increases, their effective resistance values decrease. This is due to the negative temperature coefficient of the beads. Initially, the beads are DC biased to 200 ohms. Application of RF power increases the power level present at the beads and causes the effective resistance value of the beads to drop. The bridge

circuit of the power meter reduces DC power until the initial effective resistance value is restored (200 ohms). The total amount of DC power removed is proportional to the amount of RF power that was introduced. Quantitatively, the total power applied to the thermistor beads equals the sum of the two types of power.

**Power Splitter**

The Model 2602A contains a two-element resistive power splitter. The T-shaped divider contains a series 50 ohm resistor in each of the two legs. The test port is a Type N Connector precision female connector. Use of the splitter in a closed loop configuration that applies constant power causes the common point (divider) to become a constant voltage point. This means the source impedance at both splitter output ports is determined by the 50 ohm resistor and the output connector. This provides very good source match. In addition, the power is split equally between the two ports.

**Controlling Thermistor Temperature**

Since thermistor mounts are temperature sensitive devices, it is necessary to eliminate or minimize the effects of changes in the ambient temperature. This is accomplished by thermally isolating the mount, raising its temperature with a heater element to a level higher than the ambient temperature, and maintaining that level by means of an external temperature controller. The heater element electrical assembly as illustrated in Figure 3.2. The proper temperature is determined by the characteristics of the thermistor beads.

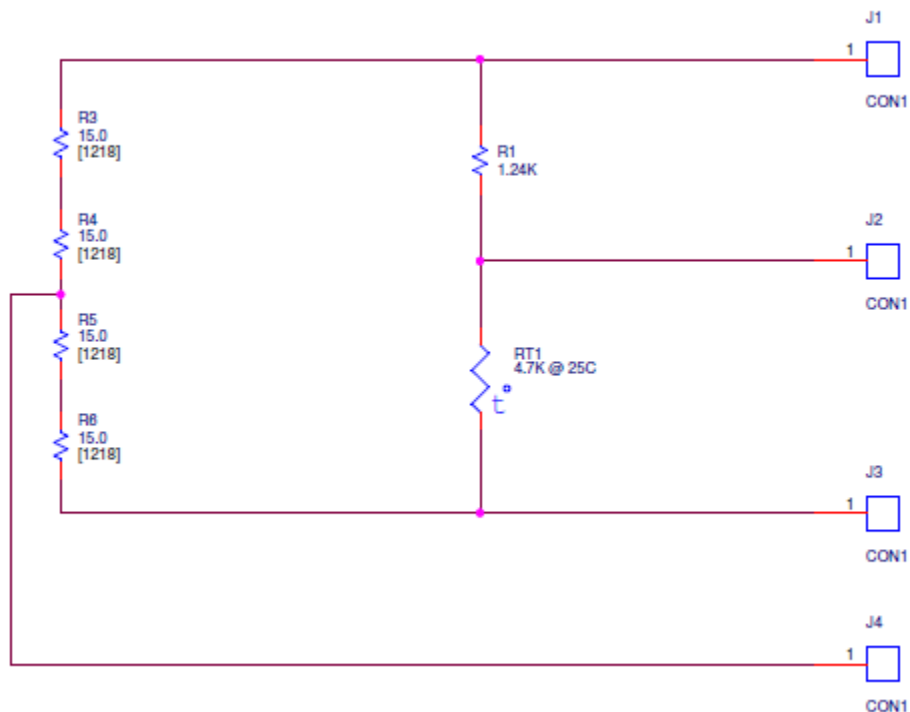
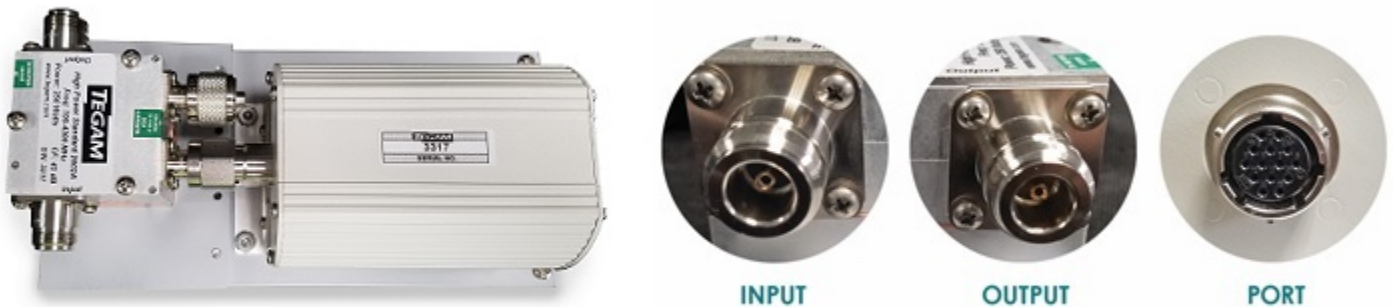

**Figure 3.2 Simplified Circuit of the RF Power Standards Internal Heater**

**General**

The TEGAM RF Power Standards are designed to be employed as the fourth arm of a bridge configuration. These units are designed as the sensing element in RF power calibration and measurement systems. The 2602A is no different other than its ability to work in a much higher power range due to the coupler located on the input. The 2602A is designed to work in a system with a calorimeter. An example of this type of system is the TEGAM Model 1314 Calorimeter. The Model 2602A is a feedthrough thermistor standard used for the calibration of Watt Meters as well as other high power RF power sensing sensors.

**Model 2602A Connector Descriptions**



**Figure 4.1 TEGAM 2602A Connectors**

**RF IN connector (Input)/ SENSOR connector (Output)**

Both the input and output connectors are Type N female. The input connects to a signal generator and the output connects to the DUT. The RF power that is present at the input connector is un-coupled to the output (DUT) port with only approximately 0.5 dB of insertion loss in the RF path. The RF power applied to the input is coupled with approximately 43dB to the attached RF power standard.

**BIAS VOLTAGE/Heater combination connector (Port)**

A combined connection is used to connect the thermistor element to a DC Substitution bridge circuit and the heater control circuit as is found in the TEGAM Model 1830A. The bridge operates on the principal of DC substitution, so only DC voltages and currents are present at these terminals when connected.

### Connecting RF Power Standards

The TEGAM RF Standards are an element of a system and is not a “stand-alone” instrument. The 2602A RF Power Standard can only be connected to the TEGAM 1830A. Unlike other TEGAM RF Power Standards, the bias and temperature are connected through one cable. To do this, simply connect one end of the appropriate cable to the 2602A and the other end to the “SENSOR” and “HEATER” connection of the 1830A. Use the appropriate cables that meet your equipment application.

The RF IN on the 2602A Power Standards is a Type N female connector. The RF IN is connected to the output of the chosen signal generator through an RF amplifier, which should be 50 Ohm nominal impedance. The coupling port connects to the standard and the through port connects to the DUT for calibration. Proper care, cleaning, alignment, and torquing of coaxial connectors should be practiced to make accurate measurements, reduce insertion loss and extend the life of the connectors.

Once cabling has been correctly installed, there are no further operator adjustments to be made to the RF Power Standards. However, allow at least two hours for the heater in the RF Standard to reach its operating temperature. Additionally, it is recommended that once the BIAS VOLTAGE terminals are connected, the DC Substitution Bridge should be on for one hour before measurements are taken.

## Calculating Calibration Factors

When using a RF Power Meter with a RF Power Sensor to make a RF Power Measurement the user must know that the measurement is accurate and there is traceability to a known standard. All diode, thermo-electric, and thermistor power sensors have calibration factors associated to particular frequencies that are used to insure an accurate power measurement. Technicians and engineers use these calibration factors when making measurements but where do these calibration factors really come from.

Calibration factor of a terminating power sensor, if it is a DC-substitution sensor, relates the change in DC substituted power to the total RF power *incident* on the sensor. For this purpose, incident means all of the RF propagating toward the sensor reference plane, including power that is subsequently reflected. On the signal flow diagram (figure 4.3), the incident power is  $P_i = |a_i|^2$ .

Calibration factor of a feed-through power calibration setup, again if the monitor is a DC-substitution sensor, relates the change in DC substituted power in the monitor to the power delivered out of the DUT port into a load of exactly the nominal characteristic impedance of the system, or  $Z_0$ . If we think of the feed-through DUT port as the output of a leveled generator, then the output into a perfect load is  $P_{gz_0}$ .

So for a terminating sensor (using the "M" subscript following Weinschel part numbering):

$$k_M = \frac{P_{SubM}}{P_i}$$

And for a feed-through standard, (using "F" to indicate "feedthrough"):

$$k_F = \frac{P_{SubF}}{P_{gz_0}}$$

Where:

$k_M$  = Calibration factor of the Terminating Mount

$k_F$  = Calibration factor of the Feed-through Mount

$P_{SubM}$  = Power measured terminating mount

$P_{SubF}$  = Power measured Feed-through mount

In all calibrations, calibration factors are transferred from a terminating reference, to a feed-through stand, and then into the DUT. In some procedures, this transfer occurs all in one session, and in others time is saved by transferring into the feed-through once and then using that feed-through calibration factor to calibrate DUT for some time.

In a perfect world, the terminating sensor would present a perfect load, and then by reorganizing the above two definitions with incident and output power equal, we would have,

$$k_M = k_F \frac{P_{SubM}}{P_{SubF}}$$

Because power sensors are always imperfect loads, additional analysis and sometimes correction is required.

Figure 4.1 shows a signal flow diagram of two one-port devices connected together. The left-hand port is the “output”, or “generator” port and is designated on the diagram using the subscript, “g”. The right-hand port is the “input”, or “load” port and is designated using the subscript “l”. It’s clear from the diagram that port reflections dominated by the Gamma vectors generally cause the power that the generator port would output into an ideal load,  $P_{gz0}$ , to not be equal to the power  $P_i$ , incident on the load. We really have to take into account the combination of reflections, or “port match” to come up with a general understanding of calibration transfer.

Start with the signal flow diagram. In this case, a Generator “g” is represented by an ideal source “s”, and its port reflection, and the sensor is termed the load, “l”.

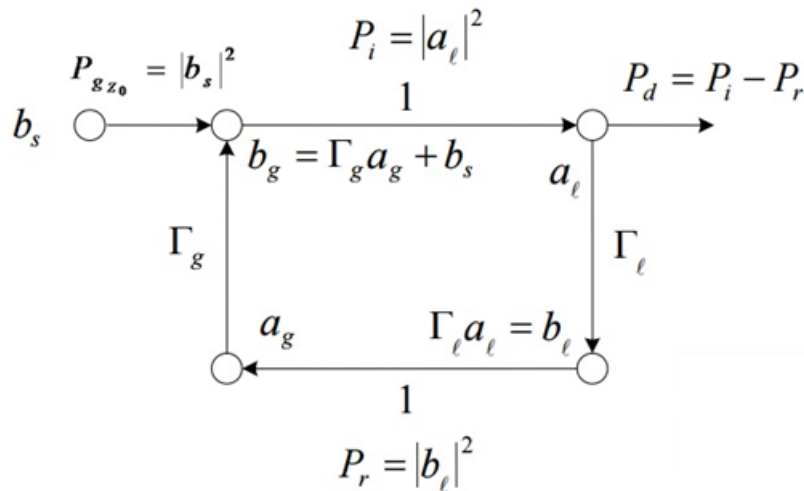

**Figure 4-3 Signal Flow Diagram**

From the diagram,

$$b_g = b_s + \Gamma_g a_g$$

But also,

$$a_g = b_l = \Gamma_l a_l = \Gamma_l b_g$$

So substituting the second equation into the first:

$$b_g = b_s + \Gamma_l \Gamma_g b_g$$

And then re-arrange to collect  $b_g$ :

$$b_g = \frac{b_s}{1 - \Gamma_l \Gamma_g}$$

Now rewrite as power, substituting in  $P_{gz0} = |b_s|^2$ , and  $P_i = |b_g|^2$ :



$$P_i = \frac{P_{g_{z0}}}{|1 - \Gamma_l \Gamma_g|^2}$$

Armed with this last result, and calling the Feed-through stand (F subscript) the “generator” (g subscript) and terminating sensor (M subscript) the “load” (l subscript), and substituting in the definitions for cal factor from earlier, we get the more general equation for transferring between a feed-through and a terminating sensor:

$$k_M = k_F \frac{P_{SubM}}{P_{SubF}} |1 - \Gamma_M \Gamma_F|^2$$

Where:

$k_M$  = Calibration factor of the Terminating Mount

$k_F$  = Calibration factor of the Feed-through Mount

$P_{SubM}$  = Power measured terminating mount

$P_{SubF}$  = Power measured Feed-through mount

$\Gamma_M$  = Gamma Correction full vector data Terminating Mount

$\Gamma_F$  = Gamma Correction full vector data Feed-through Mount

Now in this general equation, the Gamma terms are the reflection scattering parameter of the respective port noted in the subscript. Gamma is a complex vector with scalar values denoting the real and imaginary magnitudes:

$$\Gamma \equiv \rho \angle \phi = \rho \cos \phi + i \rho \sin \phi$$

In the general transfer equation, the term,  $|1 - \Gamma_M \Gamma_F|^2$  is the scalar “gamma correction” or “port match” term. Inside the absolute value brackets, however, is a *vector* subtraction. Expanding out to make the angles explicit, this becomes:

$$|1 - \rho_M \rho_F \cos(\phi_M + \phi_F) - i \rho_M \rho_F \sin(\phi_M + \phi_F)|^2$$

Where the  $i$  represents  $\sqrt{-1}$ , or the “imaginary” component.

The absolute value, or length of a vector, is given by the Pythagorean formula, which is the square root of the square of the magnitudes of the real and imaginary components. It’s convenient that we are looking for the square of the magnitude, so we don’t have to worry about the square root part. Our correction term becomes the scalar,

$$(1 - \rho_M \rho_F \cos(\phi_M + \phi_F))^2 + (\rho_M \rho_F \sin(\phi_M + \phi_F))^2$$

When the squares are evaluated, this expands to:

$$1 - 2\rho_M \rho_F \cos(\phi_M + \phi_F) + \rho_M^2 \rho_F^2 \cos^2(\phi_M + \phi_F) + \rho_M^2 \rho_F^2 \sin^2(\phi_M + \phi_F)$$

Noting that if we collect the two terms beginning with  $\rho_M^2 \rho_F^2$ , we get,

$$1 - 2\rho_M \rho_F \cos(\phi_M + \phi_F) + \rho_M^2 \rho_F^2 (\cos^2(\phi_M + \phi_F) + \sin^2(\phi_M + \phi_F))$$

The term,  $\cos^2(\phi_M + \phi_F) + \sin^2(\phi_M + \phi_F)$  is always identically equal to 1, so the final simplified equation becomes,

$$1 - 2\rho_M \rho_F \cos(\phi_M + \phi_F) + \rho_M^2 \rho_F^2$$

Or combining this result with the general transfer equation,

$$k_M = k_F \frac{P_{SubM}}{P_{SubF}} (1 - 2\rho_M \rho_F \cos(\phi_M + \phi_F) + \rho_M^2 \rho_F^2)$$

If we look at the scalar result of the mismatch term, the “1” part is what would happen if at least one of the ports was “perfect”, or had no reflection. In that case, one of the  $\rho$  is zero. The right-most element has magnitude of  $\rho^4$ , which is typically so much smaller than the middle term that it can be ignored for most connections.

The middle part,  $2\rho_M \rho_F \cos(\phi_M + \phi_F)$ , contains the bulk of the impact of port mismatch. Since it is multiplied by  $k$ , the sensitivity to this change is equal to  $k$ , or about 1. In an *UNCORRECTED* transfer, this part represents the probable error of the transfer. Since we can’t know the angles in an uncorrected transfer, we let  $\cos()$  take its limits of +/- 1, and say that the uncertainty of the uncorrected transfer is  $2\rho_M \rho_F$ . That is a little pessimistic, because that is worst-case rather than probable, but it’s what the industry usually does. Unless the rhos were measured on a scalar analyzer, we have to use manufacturer’s worst-case values.

Some common power sensor calibration practices do not always use gamma correction. An argument could probably be made that this was a reasonable practice at lower frequencies. We typically see this at 18 GHz and lower. A value of 0 would be inserted for  $\Gamma_M$  making that portion of the formula “1”.

**This would make the formula look like:**

$$k_M = k_F \frac{P_{SubM}}{P_{SubF}}$$

This revision of the original formula assumes many things that are not necessarily true. Things that may not necessarily show up at lower frequencies but will certainly show up at higher frequencies where connectors change from the very rugged N-type connector to the more sensitive 3.5 mm and 2.4 mm connectors.

By looking at Figure 4.4 we can get a practical visualization of the relationship between calibration factor, gamma and effective efficiency.



**Figure 4.4 - Relationship between calibration factor, gamma, and effective efficiency**

## Maintenance

### Calibration of 2602A

The 2602A should be calibrated periodically to maintain accuracy when using these standards. The frequency and method of calibration can vary based on the customer's requirement. TEGAM maintains full capability to calibrate these standards. Contact TEGAM to discuss your specific needs or to set up a return RMA to have your standard calibrated.

### Care and Handling of Assemblies

To ensure accurate measurements and optimal performance of TEGAM products, the microwave coaxial cable assemblies used in system and test setups must be properly used and maintained. Proper connections, routine inspection of all cables, and cleaning of the connectors are extremely important procedures which can prolong the longevity and accuracy of equipment.

### Cable Inspection

Routinely check external cables for signs of cracked insulation, dents, twists, flattening, signs of jacket abrasion, or other signs of abuse. Wrinkles in the jacket indicate that the minimum bend radius has been exceeded. Most often, this occurs near the marker tubes and connectors.

Also inspect the connector interfaces for the following:

- Bent pins (male).
- Bent or missing tines (female).
- Worn or chipped plating.
- Damaged or displaced dielectric inserts.
- Thread damage.
- Folded or mushroomed outer interface rims.
- Mushroomed pin shoulders (male) or tine ends (female).
- Score lines on pins and outer interface rims visible to the unaided eye.
- Recessed or protruding pins.

It is advisable to clean the connectors prior to inspection to make subtle damage more apparent. If any of the above is noted, replace the assembly before its further use results in equipment damage. Also inspect the mating connectors for similar damage.

Inspect the connector interface for signs of debris.

Debris may be in the form of:

- Plating chips or other metal particles.
- Dust or dirt.
- Oily films.
- Other miscellaneous foreign particles.

### Making Initial Connections

Exercise caution when mating cables. Poor connections lead to poor system performance. They can also damage not only the cable assembly, but more significantly, front or rear panel connectors on the equipment itself which may be more difficult to repair.

### Aligning Connectors

Align the center lines of two connectors before actual mating. Male retaining nuts contain a small amount of necessary play which may make it possible to mate the threads without the pins being properly aligned. Pin misalignment can damage pins and dielectric inserts.

### Mating Connectors

Gently mate the connectors by hand, taking care not to force the coupling nut at the slightest resistance. It is often possible to feel whether or not the pins are mated. If the coupling nut is difficult to turn, either the pins are not mated, the coupling nut is cross-threaded, or one of the connectors has been damaged by excess torque.

Never hold a male connector coupling nut stationary while screwing a female connector into it. This rotation can erode the plating and damage both the outer interface rim as well as the pin. If the pins become locked, serious damage can result to both the equipment and the cable assembly.

### Over-Torque

Once connectors have been properly mated, apply only the proper amount of torque. Over-torque damages both connectors involved. Also, a connector which has been damaged by over-torque, in turn, damages every connector to which it is subsequently mated. It usually leads to poor system performance as well. Over-torque can cause:

- Bent pins.
- Recessed or protruding pins.
- Recessed or protruding dielectrics.
- Chipped plating.
- Damaged coupling threads.
- Coupling nut retaining ring damage.
- Mushroomed outer interface shells.
- Mushroomed pin shoulders.

### Proper Torque of a APC Type N Connector Hex Nut

To mate a connector of the hex-nut type, always use a torque wrench set to the correct torque value. Tighten the connector slowly until the wrench snaps. Tightening too quickly can cause the wrench to exceed its set limit. Do not snap the wrench more than once as this also causes over-torque.

CONNECTOR	RECOMMENDED TORQUE
Type N Connector	12.0 in/lbs

**Figure 6.1 Recommended APC Type N Connector Torque**

**CLEANING CONNECTOR INTERFACES**

Use the following guidelines in cleaning connector interfaces:

- Do not use chlorinated solvents including common tap water. These solvents are extremely penetrating and sometimes ruin otherwise good devices and assemblies.
- Moisten a cotton swab with isopropyl alcohol. Roll the swab on a paper towel to remove excess.
- Use the moistened cotton swab to wipe away debris. Do not try to dissolve the debris by over-wetting the swab.
- Repeat the cleaning process using additional swabs as necessary. If metallic particles are embedded in the dielectric, use an eyeglass and a sharp pick in an attempt to dislodge them. Swab again.
- When satisfied that the interfaces are clean, blow them dry with dry compressed air, or preferably dry nitrogen (pressurized spray cans work well). Do not use breath.
- Clean the mating connectors. These may be the source of the debris.



**Returning 2602A for Service**

Use the information in this section if you need to return your Power Standard to TEGAM.

**Package 2602A for Shipment**

Use the following steps to package the Power Standard for shipment to TEGAM for service:

1. Fill the EXPEDITE REPAIR & CALIBRATION FORM (found in Section I) and attach it to the Power Standard. Please be as specific as possible about the nature of the problem. Send a copy of any or all of the following information:
  - o Any error messages that appeared on the power meter display.
  - o Any information on the performance of the Power Standard.
2. Use the original packaging materials or a strong shipping container. The carton must be both large enough and strong enough to accommodate the power standard and allow at least three to four inches on all sides of the power standard for packing material.
3. Seal the shipping container securely with strong nylon adhesive tape.
4. Mark the shipping container "FRAGILE, HANDLE WITH CARE" to ensure careful handling.

CAUTION: 2602A damage can result from using packaging materials other than those specified.

5. Retain copies of all shipping papers.

NOTE: Refer to page 1-6 of the introduction for information on how to obtain a RMA from TEGAM.

**Storage**

When an RF Power Standard is to be stored for extended periods, pack the instrument into a container. Place container in a clean, dry, temperature-controlled location. If instrument is to be stored in excess of 90 days, place desiccant with items before sealing container. The safe environmental limits for storage are -55° to +75° C (-67° to +167° F) at less than 95% non-condensing relative humidity.