

ARTESYN CSU550AP-3 SERIES

550 W Distributed Power System



PRODUCT DESCRIPTION

The CSU550AP-3 power supply features a very wide 90 to 264 Vac and 180 to 300 Vdc input voltage range and employs the active power factor correction to minimize input harmonic current distortion and ensure compliance with the international EN61000-3-2 standard - they have a power factor of 0.99 at full load. The power supply employs an ultra high efficiency conversion topology, together with an innovative power transformer and rectifier construction that further improves power density and reduces interconnect power losses. Users have a choice of standard I²C or advanced PMBus™ communications. The control software runs under windows on any PC.

SPECIAL FEATURES

- 550W output power
- High power and short form factor
- 1U power supply
- High density design: 17W/in³
- Active power factor correction
- EN61000-3-2 harmonic compliance
- Inrush current control
- 80 PLUS® platinum efficiency
- N+M redundant N+M ≤ 4
- Hot-pluggable
- Active current sharing
- Full digital control
- PMBus™ compliant
- Accurate input power reporting
- EN61000-4-11
- Compatible with Artesyn's Universal PMBus GUI

- Reserve airflow option
- Conducted/Radiated EMI class A

SAFETY

- UL/cUL
- TUV + CB Report
- CE Mark
- CCC
- BSMI
- KC
- TUV
- UKCA Mark

TYPICAL APPLICATIONS

- Industrial

AT A GLANCE

Total Power

550 W

Input Voltage

90 to 264 VAC
164 to 320 VDC

of Outputs

Main and standby



MODEL NUMBERS

Standard	Output Voltage	Minimum Load	Maximum Load	Stand-By Supply	Air Flow Direction
CSU550AP-3	12.15VDC	0A	45A	12VDC@2.5A	Normal (DC connector to handle)
CSU550AP-3-001	12.15VDC	0A	45A	12VDC@2.5A	Reversed (Handle to DC connector)

Options

None

ELECTRICAL SPECIFICATIONS

Absolute Maximum Ratings

Stress in excess of those listed in the “Absolute Maximum Ratings” may cause permanent damage to the power supply. These are stress ratings only and functional operation of the unit is not implied at these or any other conditions above those given in the operational sections of this TRN. Exposure to any absolute maximum rated condition for extended periods may adversely affect the power supply’s reliability.

Table 1. Absolute Maximum Ratings							
Parameter	Models	Symbol	Min	Typ	Max	Unit	
Input Voltage	AC continuous operation	All models	$V_{IN,AC}$	90	-	264	Vac
	DC continuous operation						$V_{IN,DC}$
Maximum Output Power (Main + Standby)	All models	$P_{O,max}$	-	-	550	W	
Isolation Voltage	Input to outputs	All models	-	-	4242	Vdc	
	Input to safety ground	All models	-	-	2751	Vdc	
Ambient Operating Temperature ¹	All models	T_A	0	-	+55	°C	
Storage Temperature	All models	T_{STG}	-40	-	+70	°C	
Humidity (non-condensing)	Operating	All models	5	-	85	%	
	Non-operating	All models	5	-	95	%	
Altitude	Operating	All models	-	-	5,000	m	
	Non-operating	All models	-	-	15,200	m	

Note 1 - Please refer to operating temperature for details.

ELECTRICAL SPECIFICATIONS

Input Specifications

Table 2. Input Specifications						
Parameter	Condition	Symbol	Min	Typ	Max	Unit
Operating Input Voltage, AC	All	$V_{IN,AC}$	90	115/230	264	VAC
Operating Input Voltage, DC	All	$V_{IN,DC}$	164	-	320	VDC
Input AC Frequency	All	$f_{IN,AC}$	47	50/60	63	Hz
AC Turn On Voltage ¹	All		79	-	89	VAC
AC Turn Off Voltage ¹	All		75	-	85	VAC
AC Input Over Voltage Protection	All		285	-	300	VAC
AC Input Recovery	All		275	-	285	VAC
Maximum Input Current ($I_O = I_{O,max}$, $I_{SB} = 0A$)	$V_{IN,AC} = 90VAC$	$I_{IN,max}$	-	-	8	A
No Load Input Power ($V_O = On$, $I_O = 0A$, $I_{SB} = 0A$)	All	$I_{IN,no-load}$	-	-	5	W
Harmonic Line Currents	All	THD	Per EN 61000-3-2			
Power Factor	$I_O > 10\%I_{O,max}$	PF	0.89	-	-	
Startup Surge Current (Inrush) @ 25°C	$V_{IN,AC} = 264VAC$	$I_{IN,surge}$	-	-	10	Apk
Input Fuse	Internal, L 5x20mm, Quick Acting 10A, 420VDC		-	-	10	A
Leakage Current to Earth Ground	$V_{IN,AC} = 264VAC$ $f_{IN,AC} = 50Hz$		-	-	0.85	mA
Operating Efficiency ² @ 25°C	$V_{IN,AC} = 230VAC$ $f_{IN,AC} = 50Hz$ $I_O = 10\%I_{O,max}$ $I_O = 20\%I_{O,max}$ $I_O = 50\%I_{O,max}$ $I_O = 100\%I_{O,max}$	η	88	-	-	%
			91	-	-	%
			94	-	-	%
			91	-	-	%
System Stability	Phase Margin		45	-	-	°
	Gain Margin		10	-	-	dB

Note 1 - Turn on/off hysteresis is $\geq 5V$.
 Note 2 - Measured excluding fan power.

ELECTRICAL SPECIFICATIONS

Output Specifications

Table 3. Output Specifications						
Parameter	Condition	Symbol	Min	Typ	Max	Unit
Factory Set Voltage	All	V_O	12.05	12.15	12.25	V
		V_{SB}	12.05	12.2	12.25	
Output Regulation	Inclusive of set-point, temperature change, warm-up drift and dynamic load	V_O	11.4	12.15	12.6	V
		V_{SB}	11.4	12.2	12.6	
Output Ripple, pk-pk	Measure with a 0.1 μ F ceramic capacitor in parallel with a 10 μ F tantalum capacitor, 0 to 20MHz bandwidth	V_O	-	-	120	mV _{PK-PK}
		V_{SB}	-	-	120	
Output Current	All	I_O	0	-	45	A
	All	I_{SB}	0	-	2.5	
Output Current Share Accuracy	20% to 100% $I_{O,max}$ 15% to 25% $I_{O,max}$		- -	- -	5 10	% _O
Output Voltage Minimum Current Share Loading	All		15	-	-	%
Number of Parallel Units ¹	Main output “12V load share” connected		-	-	4	
Load Capacitance	Start Up	V_O	500	-	25000	μ F
		V_{SB}	100	-	3100	μ F
V_O Dynamic Response ² Peak Deviation	60% load change, slew rate = 0.5A/ μ s	V_O	11.4	-	12.6	V
	1A load change, slew rate = 0.5A/ μ s	V_{SB}	11.4	-	12.6	V

Note 1 - V_{SB} output do not use active current sharing. On paralleled units, the maximum current on V_{SB} output rail can not exceed the current of one unit.
 Note 2 - Recommend to test with 2200 μ F capacitive load at the V_O output and 1000 μ F at V_{SB} output. 1A minimum current for transient load response testing only.

ELECTRICAL SPECIFICATIONS

System Timing Specifications

Table 4. System Timing Specifications					
Label	Parameter	Min	Typ	Max	Unit
T1	Delay from AC being applied to V_{SB} being within regulation	-	-	1500	mSec
T2	Delay from AC being applied to all output voltages being within regulation	-	-	3000	mSec
T3	V_o rise time, 0V to V_o in regulation	5	-	70	mSec
T4	Delay from output voltages within regulation limits to PWOK asserted high at turn on	100	-	500	mSec
T5	Delay from loss of AC to de-assertion of PWOK	12	-	-	mSec
T6	Delay from PWOK de-asserted to output voltages dropping out of regulation limits	1	-	-	mSec
T7	Hold up time - time output voltages stay within regulation after the loss of AC at 100% load *The hold-up time will be >20ms at 50% load.	13	-	-	mSec
T8	Delay from standby voltage in regulation to output voltage in regulation at AC turn on	50	-	1000	mSec
T9	Duration of PWOK being in the de-asserted state during an off/on cycle using AC or the PSON signal	100	-	-	mSec
T10	Delay from PSON active to output voltages within regulation limits	5	-	400	mSec
T11	Delay from PSON de-active to PWOK de-asserted low	-	-	5	mSec
T12	Hold up time - time standby voltages stay within regulation after the loss of AC	70	-	-	mSec

ELECTRICAL SPECIFICATIONS

System Timing Diagram

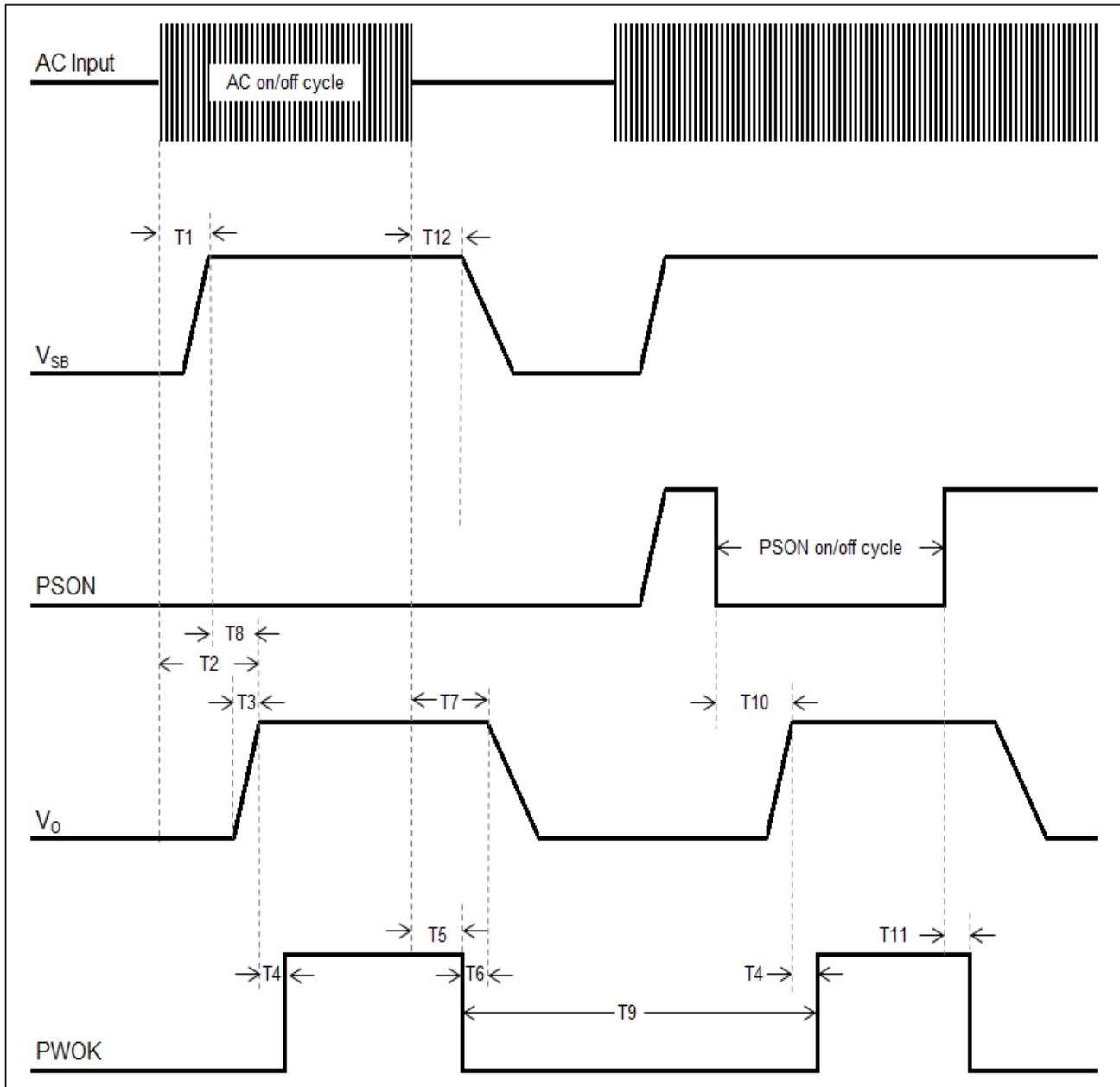

ELECTRICAL SPECIFICATIONS

CSU550AP-3 Performance Curves

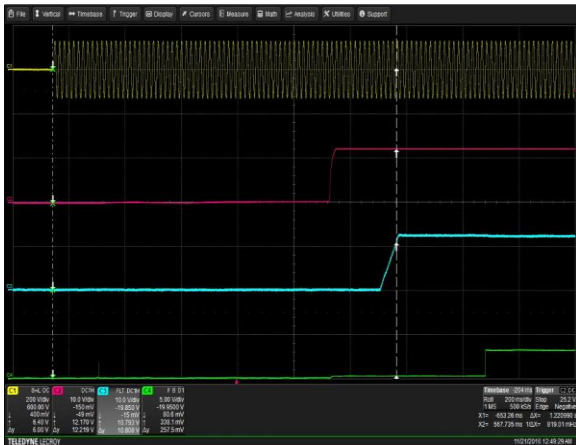

Figure 1: CSU550AP-3 Turn-on delay via AC mains
 Vin = 90VAC Load: Io = 45A I_{SB} = 2.5A
 Ch 1: AC Mains Ch 2: V_{SB} Ch 3: V_O Ch 4: PWOK

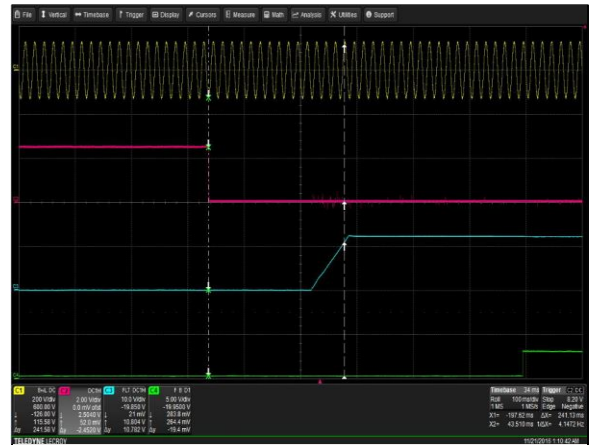

Figure 2: CSU550AP-3 Turn-on delay via PSON
 Vin = 90VAC Load: Io = 45A I_{SB} = 2.5A
 Ch 1: AC Mains Ch 2: V_{SB} Ch 3: V_O Ch 4: PWOK

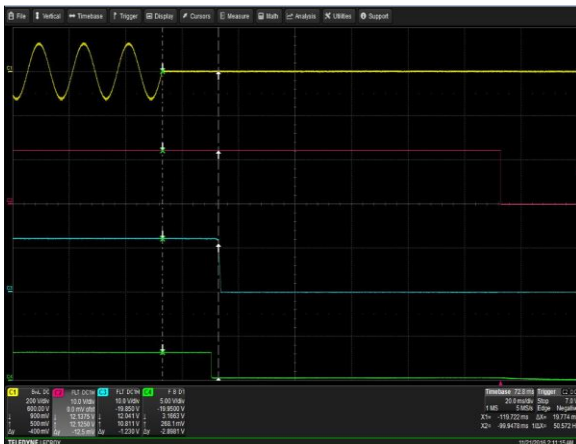

Figure 3: CSU550AP-3 Hold-up Time
 Vin = 90VAC/63Hz/0° Load: Io = 45A I_{SB} = 2.5A
 Ch 1: AC Mains Ch 2: V_{SB} Ch 3: V_O Ch 4: PWOK

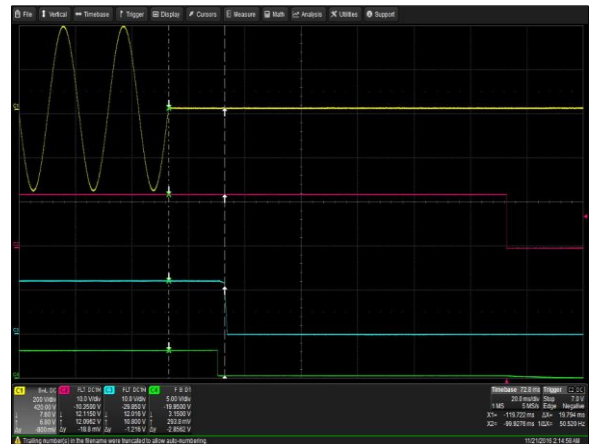

Figure 4: CSU550AP-3 Hold-up Time
 Vin = 264VAC/47Hz/0° Load: Io = 45A I_{SB} = 2.5A
 Ch 1: AC Mains Ch 2: V_{SB} Ch 3: V_O Ch 4: PWOK



Figure 5: CSU550AP-3 Output Voltage Startup Characteristic
 Vin = 90VAC Load: Io = 45A I_{SB} = 2.5A
 Ch 3: V_O Ch 4: PWOK

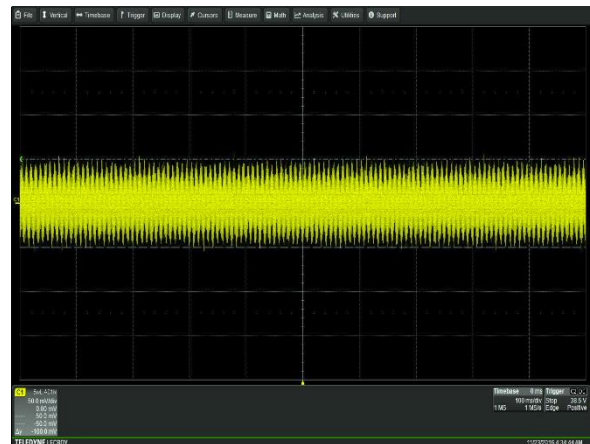

Figure 6: CSU550AP-3 Ripple and Noise Measurement
 Vin = 90VAC Load: Io = 45A I_{SB} = 2.5A
 Ch 3: V_O Ch 4: PWOK

ELECTRICAL SPECIFICATIONS

CSU550AP Performance Curves



Figure 7: CSU550AP-3 Turn Off Characteristic via PSON
 Load: $I_o = 45A$ $I_{SB} = 2.5A$
 Ch 1: PSON Ch 2: V_o Ch 3: PWOK



Figure 8: CSU550AP-3 Transient Response - V_o Deviation (low to high)
 50% to 100% load change, $0.25A/\mu S$ slew rate, $V_{in} = 230Vac$
 Ch 1: V_o Ch 2: I_o

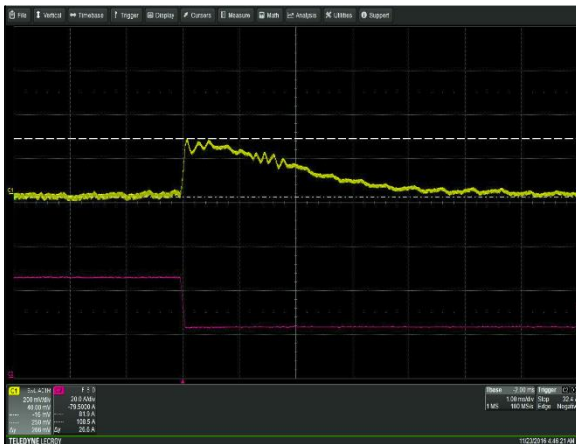

Figure 9: CSU550AP-3 Transient Response - V_o Deviation
 100% to 40% load change, $0.5A/\mu S$ slew rate, $V_{in} = 230Vac$
 Ch 1: V_o Ch 2: I_o

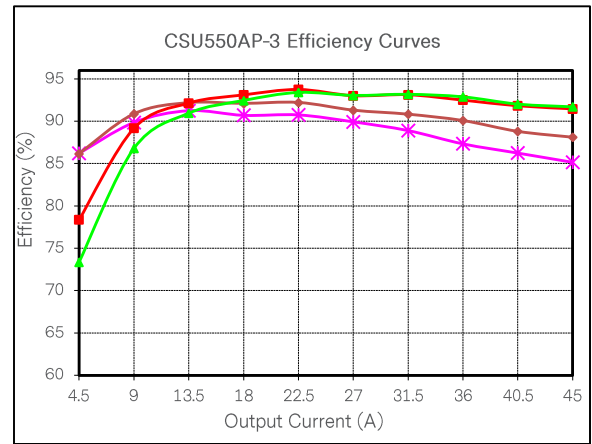

Figure 10: CSU550AP-3 Efficiency Curve @ 25°C
 Loading: $I_{o_main} = 10\%I_{o_max}$ increment to 45A, $I_{SB} = 0A$ (12V)

Note 1 - All waveforms and data are tested on CSU550AP-400.

ELECTRICAL SPECIFICATIONS

Protection Function Specifications

Input Fuse

CSU550AP series is equipped with an internal non user serviceable 10A High Rupturing Capacity (HRC) 420Vdc fuse to IEC 127 for fault protection on L lines input.

Over Voltage Protection (OVP)

The power supply over voltage protection is locally sensed. The power supply shuts down and latches off after an over voltage condition occurs. This latch can be cleared by toggling the PSON signal or by an AC power interruption. The values are measured at the output of the power supply's connectors. The voltage never exceeds the maximum levels when measured at the power connectors of the power supply connector during any single point of fail. The voltage never trips any lower than the minimum levels when measured at the power connector. +12V VSB is auto-recovered after removing OVP limit.

Parameter	Min	Nom	Max	Unit
Main Output Overvoltage	13.2	/	14.5	V
Standby Output Overvoltage	13.3	/	14.5	V

Over Temperature Protection (OTP)

The power supply is protected against over temperature conditions caused by loss of fan cooling or excessive ambient temperature. In an OTP condition the PSU will shutdown. When the power supply temperature drops to within specified limits, the power supply will restore power automatically, while the +12V VSB remains always on. The OTP circuit has built in margin such that the power supply will not oscillate on and off due to temperature recovering condition. The OTP trip level has a minimum of 4°C of ambient temperature margin.

Over Current Protection (OCP)

The power supply has current limit to prevent the outputs from exceeding the values shown in table below. If the current limits are exceeded the power supply will shutdown and latch off. The latch can be cleared by toggling the PSON signal or by an AC power interruption. The power supply will not be damaged from repeated power cycling in this condition. +12V VSB is auto recovered after removing OCP limit.

Parameter	Min	Nom	Max	Unit
Main Output Over current	55	/	62	A
Standby Output Over current	3.0	/	4.5	A

MECHANICAL SPECIFICATIONS

Mechanical Outlines (unit: mm)

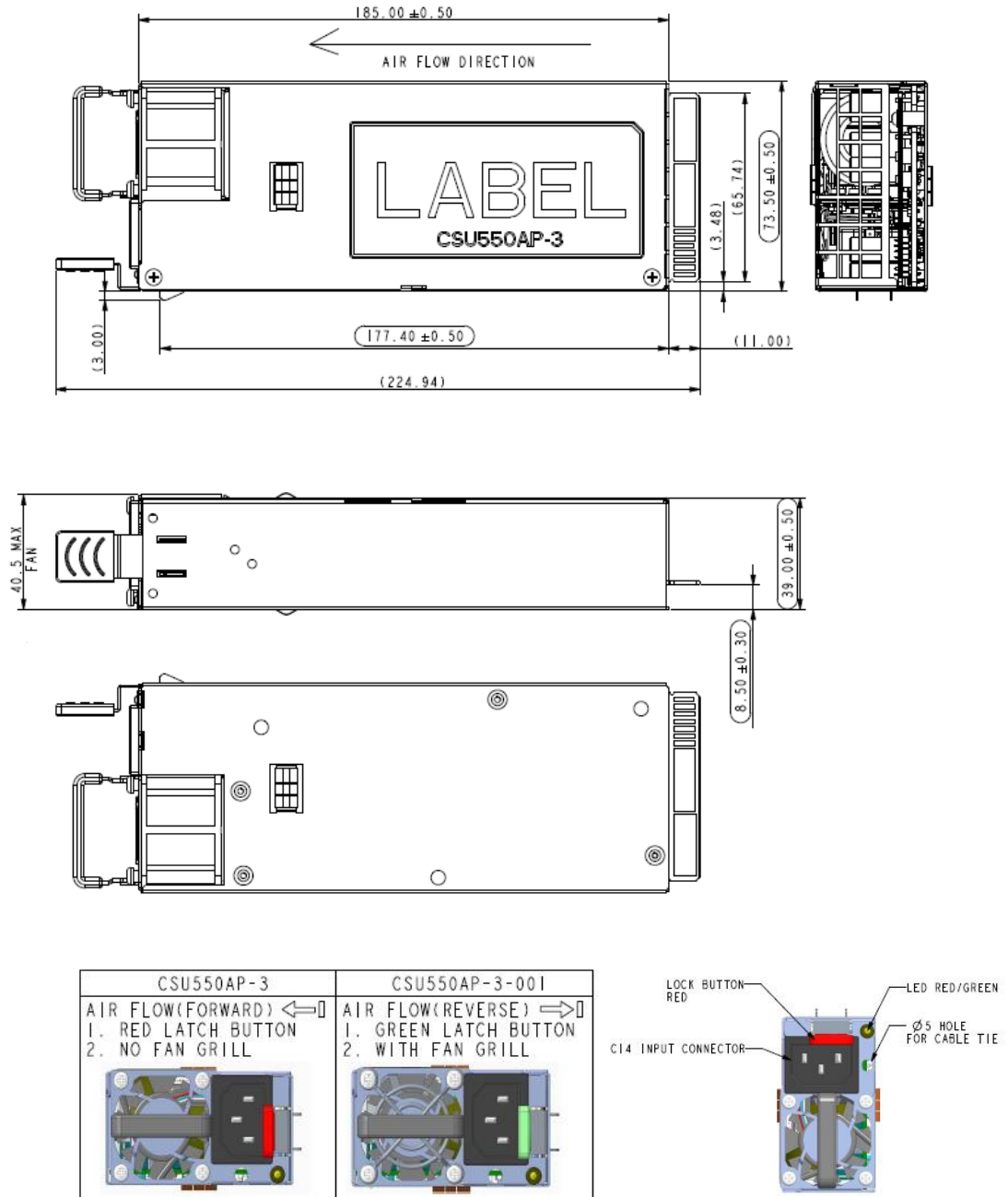

MECHANICAL SPECIFICATIONS

Connector Definitions

AC Input Connector

Pin 1	-	L
Pin 2	-	N
Pin 3	-	Earth Ground

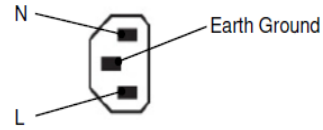

Output Connector - Power Blades

A1-A9	-	Main Output Return
A10-A18	-	+ Main Output (V_O)
B1-B9	-	Main Output Return
B10-B18	-	+ Main Output (V_O)

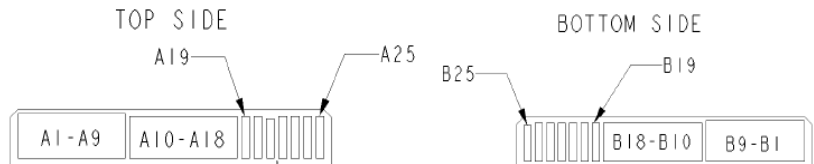

Output Connector - Control Signals

A19	-	SDA
A20	-	SCL
A21	-	PSON
A22	-	SMBAlert#
A23	-	-VSENSE
A24	-	+VSENSE
A25	-	PWOK
B19	-	A0 (SMBus address)
B20	-	A1 (SMBus address)
B21	-	12V _{SB}
B22	-	CR_BUS#
B23	-	12V load share
B24	-	Present
B25	-	Reserved

View from power supply output connector end

MECHANICAL SPECIFICATIONS

Power / Signal Mating Connectors and Pin Types

Table 5. Mating Connectors for CSU550AP-3		
Reference	On Power Supply	Mating Connector or Equivalent
AC Input Connector	IEC320-C14	IEC320-C13
Output Connector	Card-edge	2x25 pin configuration of the FCI power card connector 10035388-102LF

MECHANICAL SPECIFICATIONS

LED Indicator Definitions

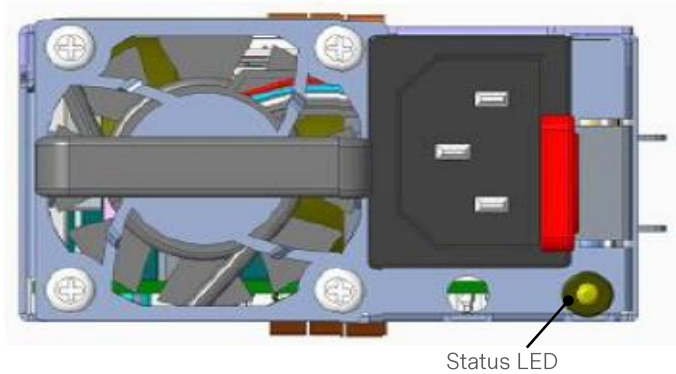

One bi-color (green/amber) LED at the power supply front provides the status signal. The status LED conditions are shown on the following table.

Conditions	LED Status
$V_{SB} = ON$, $V_O = OFF$, AC Input = ON Power supply is cold standby state or always cold standby state as defined in the Cold Redundancy section of the CSU550AP series Common Requirements Specification	1Hz Blinking Green
$V_{SB} = ON$, $V_O = ON$	Solid Green
$V_O = OCP / UVP / OVP / FAN_FAULT / OTP$ $V_{SB} = OCP/UVP$ AC cord unplugged or AC power lost; with a second power supply in parallel still with AC input power	Red
Power supply warning events where the power supply continues to operate; high temp, high power, high current, slow fan	1Hz Blink RED
AC Input = OFF	OFF
Power supply FW updating	2Hz Blink GREEN

MECHANICAL SPECIFICATIONS

Weight

The CSU550AP weight is 741.6g/1.63lbs.

ENVIRONMENTAL SPECIFICATIONS

EMC Immunity

CSU550AP-3 power supply is designed to meet the following EMC immunity specifications.

Table 6. Environmental Specifications	
Document	Description
Class A of CISPR22 (EN55032) and FCC Part 15	Conducted and Radiated EMI Limits
EN61000-3-2 Class A	Harmonics
IEC/EN61000-3-3	Voltage Fluctuations
IEC/EN61000-4-2	Electromagnetic Compatibility (EMC) - Testing and measurement techniques - Electrostatic discharge immunity test: +/-15KV air, +/-8KV contact discharge. Performance - Criteria B
IEC/EN61000-4-3	Electromagnetic Compatibility (EMC) - Testing and measurement techniques - Radiated, radio-frequency, electromagnetic field immunity test, 10V/m Performance - Criteria A
IEC61000-4-4	Electromagnetic Compatibility (EMC) - Testing and measurement techniques - Electrical fast transient/burst immunity test: +/-2KV for AC power port Performance - Criteria B
IEC/EN61000-4-5	Electromagnetic Compatibility (EMC) - Testing and measurement techniques - Surge test: +/-2KV common mode and +/-1KV differential mode for AC ports Performance - Criteria B
IEC/EN61000-4-11	Electromagnetic Compatibility (EMC) - Testing and measurement techniques: Voltage Dips and Interruptions: >95% reduction for 10ms: Criteria B 30% reduction for 500mS: Criteria C >95% reduction for 5000mS: Criteria C

ENVIRONMENTAL SPECIFICATIONS

Safety Certifications

The CSU550AP power supply is intended for inclusion in other equipment and the installer must ensure that it is in compliance with all the requirements of the end application. This product is only for inclusion by professional installers within other equipment and must not be operated as a stand-alone product.

Table 7. Safety Certifications for CSU550AP-3 Power Supply System		
Standard	Certificate No.	Description
UL 60950-1, CAN/CSA C22.2 No. 60950-1	E132002-A415-UL	US and Canada Requirements
UL 62368-1, CAN/CSA C22.2 No. 62368-1	E132002-A6119-UL	US and Canada Requirements
IEC/EN 62368-1:2014	/	European Requirements
CB Certificate and report	DK-82414-A1-UL	(All CENELEC Countries)
CHINA CCC Approval	2016010907874664	China Requirements
KC	MSIP-REM-AIL-CSU550AP-3	Korea Requirements
BSMI	C1335061603026 99	Taiwan Requirements
CE Mark	/	LVD+RoHS
UKCA Mark	/	LVD+RoHS

ENVIRONMENTAL SPECIFICATIONS

EMI Emissions

The CSU550AP series power supply has been designed to comply with the Class A limits of EMI requirements of FCC Part 15 and CISPR 22 (EN55032) for emissions and relevant sections of EN55032:2012 for immunity. The unit is enclosed inside a metal box, tested at 550W using resistive load with the cooling fan.

Conducted Emissions

The applicable standard for conducted emissions is EN55032 (FCC Part 15). Conducted noise can appear as both differential mode and common mode noise currents. Differential mode noise is measured between the two input lines, with the major components occurring at the supply fundamental switching frequency and its harmonics. Common mode noise, a contributor to both radiated emissions and input conducted emissions, is measured between the input lines and system ground and can be broadband in nature.

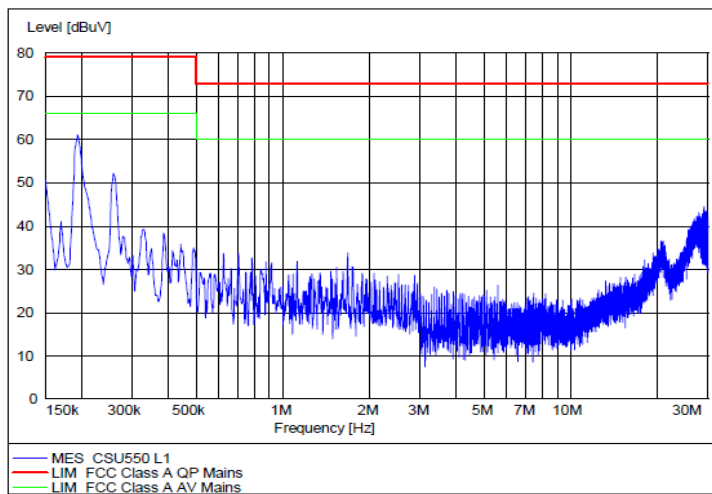

The CSU550AP-3 power supply has internal EMI filters to ensure the converters' conducted EMI levels comply with EN55032 (FCC Part 15) Class A limits. The EMI measurements are performed with resistive loads at maximum rated loading.

Sample of EN55032 Conducted EMI Measurement at 110Vac Input

Note: Red Line refers to Artesyn Quasi Peak margin, which is 6dB below the CISPR international limit. Green Line refers to the Artesyn Average margin, which is 6dB below the CISPR international limit.

Conducted EMI emissions specifications of the CSU550AP series:

Parameter	Model	Symbol	Min	Typ	Max	Unit
FCC Part 15, class A	All	Margin	-	-	6	dB
CISPR 22 (EN55032), class A	All	Margin	-	-	6	dB

Radiated Emissions

Unlike conducted EMI, radiated EMI performance in a system environment may differ drastically from that in a stand-alone power supply. The shielding effect provided by the system enclosure may bring the EMI level from Class A to Class B. It is thus recommended that radiated EMI be evaluated in a system environment. The applicable standard is EN55032 Class A (FCC Part 15). Testing AC-DC converters as a stand-alone component to the exact requirements of EN55032 can be difficult because the standard calls for 1m lead to be attached to the input and outputs and aligned such as to maximize the disturbance. In such a set-up, it is possible to form a perfect dipole antenna that very few AC-DC converters could pass. However, the standard also states that an attempt will be made to maximize the disturbance consistent with the typical application by varying the configuration of the test sample.

ENVIRONMENTAL SPECIFICATIONS

Operating Temperature

The CSU550AP power supply starts and operates within stated specifications at an ambient temperature from 0°C to 50°C. The maximum operating temperature (50°C) is to be de-rated by 1°C per 300m above 2000m.

Forced Air Cooling

The CSU550AP power supply includes internal cooling fans as part of the power supply assembly to provide forced air-cooling to maintain and control the temperature of devices and ambient temperature in the power supply to appropriate levels. The standard direction of airflow is from the DC connector end to the AC connector end of the power supply.

Storage and Shipping Temperature

The CSU550AP series power supplies can be stored or shipped at temperatures between -40 °C to +70 °C and relative humidity from 5% to 95% non-condensing.

Altitude

The CSU550AP series operates within specifications at altitudes up to 5,000 meters above sea level. The power supply will not be damaged when stored at altitudes of up to 15,200 meters above sea level.

Humidity

The CSU550AP series operates within specifications when subjected to a relative humidity from 5% to 85% non-condensing. The CSU550AP series can be stored in a relative humidity from 5% to 95% non-condensing.

ENVIRONMENTAL SPECIFICATIONS

Vibration

The CSU550AP power supplies pass the following vibration specifications:

Non-Operating Random Vibration

Acceleration	1.87		gRMS
Frequency Range	10 - 500		Hz
Duration	30		Mins
Direction	3 mutually perpendicular axis		
PSD Profile	FREQ (Hz)	SLOPE (db/oct)	PSD (g ² /Hz)
	10 - 200	/	0.01
	500	/	0.003

Operating Random Vibration

Acceleration	0.15		gRMS
Frequency Range	5 - 100		Hz
Duration	30		Mins
Direction	3 mutually perpendicular axis		
PSD Profile	FREQ (Hz)	SLOPE (db/oct)	PSD (g ² /Hz)
	5	/	0.000025
	10 - 50	/	0.0004
	100	/	0.000025

Shock

The CSU550AP power supplies pass the following shock specifications:

Non-Operating Half-Sine Shock

Acceleration	30	G
Duration	11	mSec
Pulse	Half-Sine	
Number of Shock	3 shocks in each of 6 directions	

Operating Half-Sine Shock

Acceleration	4	G
Duration	22	mSec
Pulse	Half-Sine	
Number of Shock	3 shocks in each of 6 directions	

POWER AND CONTROL SIGNAL DESCRIPTIONS

AC Input Connector

This connector supplies the AC Mains to the CSU550AP-3 power supply.

- Pin 1 - L
- Pin 2 - N
- Pin 3 - Earth Ground

Output Connector - Power Blades

These pins provide the main output for the CSU550AP-3. The + Main Output (V_O) and the Main Output Return pins are the positive and negative rails, respectively, of the V_O main output of the CSU550AP power supply. The main output return is not isolated to the power supply chassis.

- A1-A9 - Main Output Return
- A10-A18 - Main Output (V_O)
- B1-B9 - Main Output Return
- B10-B18 - Main Output (V_O)

Output Connector - Control Signals

The CSU550AP series contains a 14 pins control signal header providing an analogue control interface, standby power and I²C interface signal connections.

PSON - (Pin A21)

The PSON signal is an active Low and it enables power supply 12V main output.

Signal Type	Accepts an open collector/drain input from the system. Pull-up to VSB located in power supply	
PSON# = Low	ON	
PSON# = High or Open	OFF	
	Min	Max
Logic Level low (power supply ON)	0V	1.0V
Logic Level low (power supply OFF)	2.0V	3.46V
Source current, $V_{pson} = \text{low}$		4mA
Power up delay: $T_{pson_on_delay}$	5ms	400ms
PWOK delay: T_{pson_pwok}		50ms

POWER AND CONTROL SIGNAL DESCRIPTIONS

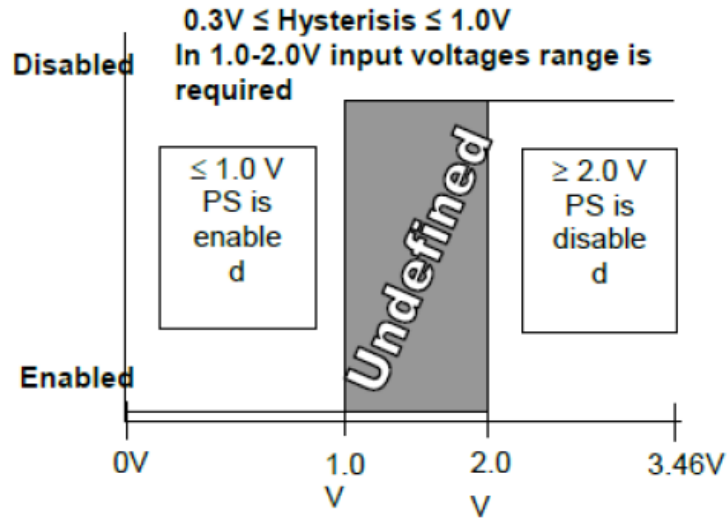

Power supply side

Customer system side

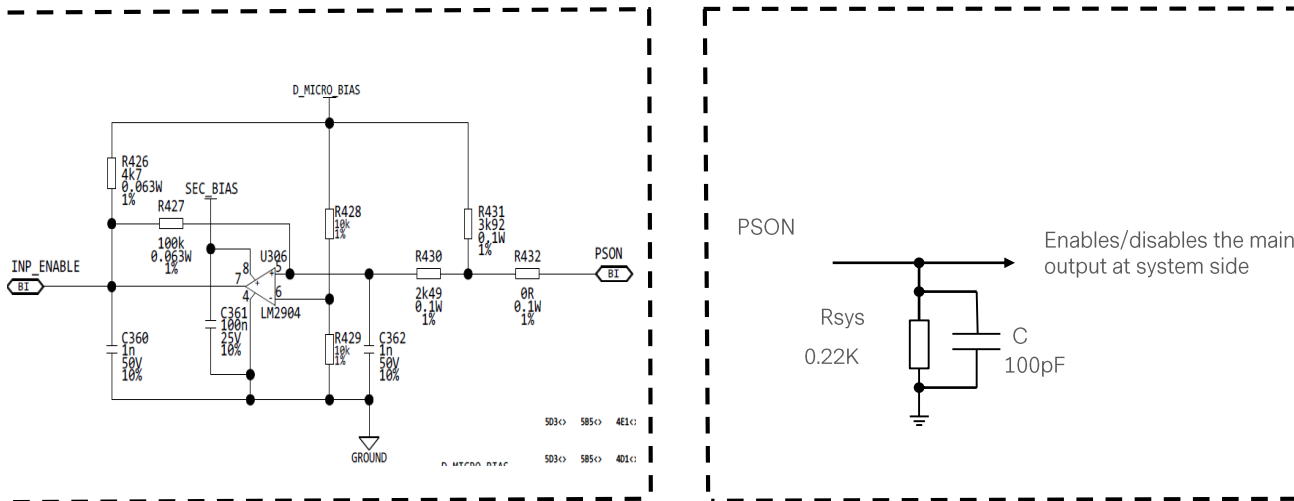

SMBALERT# - (Pin A22)

This signal indicates that the power supply is experiencing a problem that the user should investigate. This will be asserted due to Critical events or Warning events. The signal will activate in the case of critical component temperature reached a warning threshold, general failure, over-current, over-voltage, under-voltage, failed fan. This signal may also indicate the power supply is reaching its end of life or is operating in an environment exceeding the specified limits. Upon the default setting, the conditions under which the alert will be asserted include IOUT_OC_WARNING, VIN_UV_FAULT, and OT_WARNING.

This signal is to be asserted in parallel with LED turning solid Red or blink Red.

POWER AND CONTROL SIGNAL DESCRIPTIONS

Signal Type	Accepts an open collector/drain input from the system. Pull-up to VSB located in power supply	
Alert # = High	OK	
Alert # = Low	Power alert to system	
	Min	Max
Logic level low voltage, Isink = 4mA	0V	0.4V
Logic level high voltage, Isink = 50uA		3.46V
Sink current, Alert# = low		4mA
Sink current, Alert# = high		50μA
Alert # rise and fall time		100μS

+VSENSE & -VSENSE - (Pins A23, A24)

+VSENSE and -VSENSE are the remote sense signals for 12V main output voltage.

PWOK - (Pin A25)

PWOK is an active High output which is used to indicate that Power is OK. Specifically it indicates:

The PWOK signal is active low.

The 12V main output voltage is normal.

The 12V standby output voltage is normal.

The 12V main load is below OCP threshold.

The 12V standby load is below OCP threshold.

The power supply is operating within thermal limits.

If any of these conditions are not true then PWOK will be pulled low by the power supply.

Signal Type	Accepts an open collector/drain input from the system. Pull-up to VSB located in power supply	
PWOK = High	Power ON	
PWOK = Low	Power Not OK	
	Min	Max
Logic Level low voltage, Isink = 4mA	0V	0.4V
Logic Level high voltage, Isource = 200μA	2.4V	3.46V
Sink current, PWOK = low		4mA
Source current, PWOK = high		2mA
PWOK delay: Tpwok on	100ms	1000ms
PWOK rise and fall time		100us
Power down delay: Tpwok_off	1ms	200ms

POWER AND CONTROL SIGNAL DESCRIPTIONS

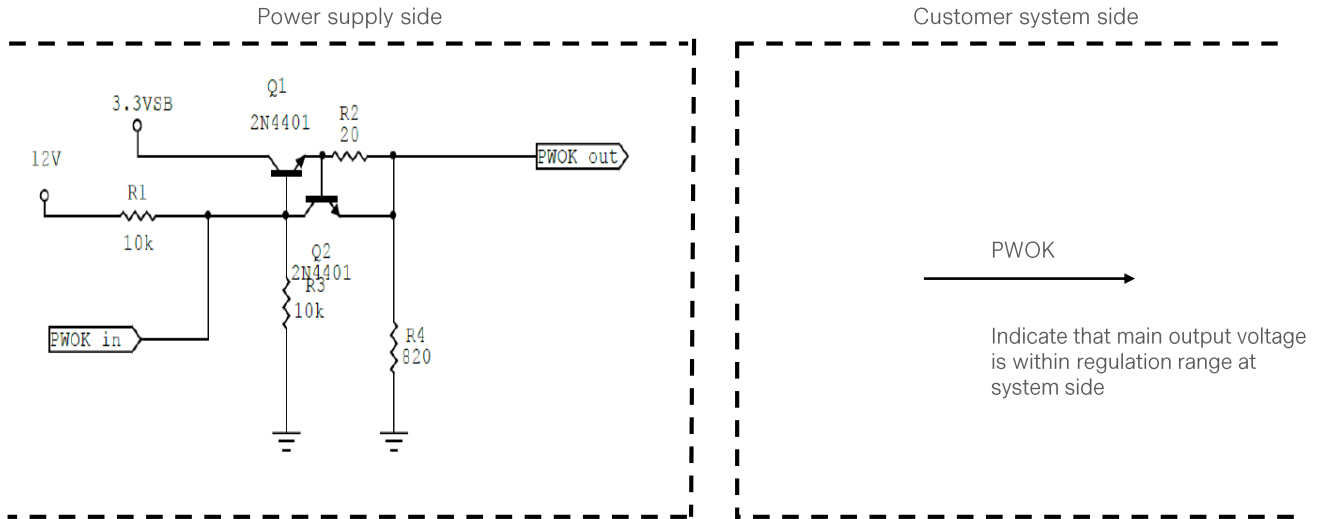

CR_BUS# - (Pin B22)

There is an additional signal defined supporting Cold Redundancy. This is connected to a bus shared between the power supplies: CR_BUS#. This is a tri-state output signal of the power supply used to communicate a fault or Vout under voltage level has occurred in one of the power supplies. This is used to power on all the power supplies in the system via the CR_BUS#. When the signal is pulled high it allows all power supplies in cold standby mode to go into cold standby state when the load share voltage is below the VCR_ON level. When the signal is left open on all power supplies it forces all cold standby power supplies into the ON.

12V load share - (Pin B23)

12V load share is a single wire bus signal used to help equalize the output current from two or more power supplies connected to a common load. 12V load share should be taken that with two or more power supplies sharing current, the percentage is the combined current for all power supplies, not one. The voltage on the 12V load share line represents the percentage of rated output current each supply is providing. 0V is equivalent to 0% load, and 8V is equivalent to 100% load. 12V load share transients during hot insertion or removal will not cause the supply output to go out of regulation.

% Max Loading	12V load share Voltage (+/-5% tolerance above 20% load)
25%	2.0 V
50%	4.0 V
100%	8.0 V

Present - (Pin B24)

This signal is used to indicate to the system that a power supply is inserted in the power bay. This pin is internally pulled down to the standby return in the power supply with a 100 ohm resistor. The recommended pull-up resistor to 12V_{SB} is 8.2k ohm with a 3.0k ohm pull down to ground. A 100pF decoupling capacitor is also recommended.

- Low - PS is present
- High - PS is removed from system

COMMUNICATION BUS DESCRIPTIONS

I²C Bus Signals

CSU550AP power supply contains enhanced monitor and control functions implemented via the I²C bus. The CSU550AP I²C functionality (PMBus™ and FRU data) can be accessed via the output connector control signals. The communication bus is powered either by the internal 3.3V supply or from an external power source connected to the standby output (i.e. accessing an unpowered power supply as long as the standby output of another power supply connected in parallel is on).

If units are connected in parallel or in redundant mode, the standby outputs must be connected together in the system. Otherwise, the I²C bus will not work properly when a unit is inserted into the system without the DC source connected.

Note: PMBus™ functionality can be accessed only when the PSU is powered-up. Guaranteed communication I²C speed is 100KHz.

A0, A1 (I²C Address Signals) - (Pins B19, B20)

These input pins are the address lines A0 and A1 to indicate the slot position the power supply occupies in the power bay and define the power supply addresses for FRU data and PMBus™ data communication. This allows the system to assign different addresses for each power supply. During I²C communication between the system and power supplies, the system will be the master and the power supplies will be the slave. They are internally pulled up to internal 3.3V supply with a 10K ohm resistor.

SDA, SCL (I²C Data and Clock Signals) - (Pins A19, A20)

I²C serial data and clock bus - these pins are internally pulled up to internal 3.3V supply with a 10K ohm resistor. These pins must be pulled-up by a 2K-10K ohm resistor to 3.3V or 5V at the system side.

I²C Bus Communication Interval

The interval between two consecutive I²C communications to the power supply must be at least 15ms to ensure proper monitoring functionality.

I²C Bus Signal Integrity

The noise on the I²C bus (SDA, SCL lines) due to the power supply will be less than 300mV peak-to-peak. This noise measurement should be made with an oscilloscope bandwidth limited to 100MHz. Measurements must be made at the power supply output connector with 10K ohm resistor pulled up to standby output and 47pF ceramic capacitors to standby output return.

COMMUNICATION BUS DESCRIPTIONS

I²C Bus Internal Implementation, Pull-ups and Bus Capacitances

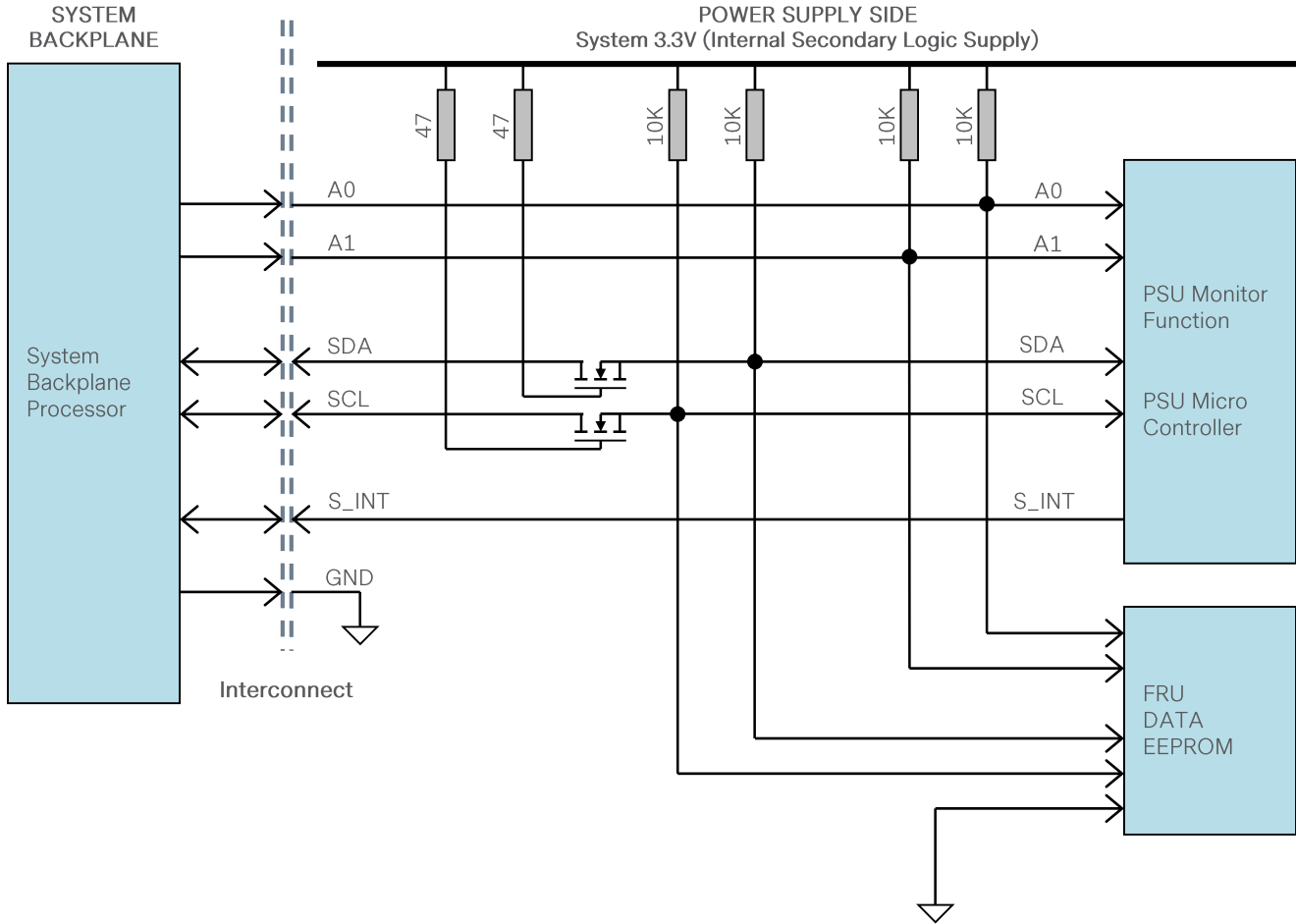

I²C Bus - Recommended external pull-ups

Electrical and interface specifications of I²C signals (referenced to standby output return pin, unless otherwise indicated):

Parameter	Condition	Symbol	Min	Type	Max	Unit
SDA, SCL Internal Pull-up Resistor		R_{int}	-	10	-	Kohm
SDA, SCL Internal Bus Capacitance		C_{int}	-	10	-	pF
Recommended External Pull-up Resistor	1 to 4 PSU	R_{ext}	-	2.2	-	Kohm

COMMUNICATION BUS DESCRIPTIONS

Logic Levels

CSU550AP power supply I²C communication bus responds to logic levels as per below:

Logic High: 3.3V nominal (Spec is 2.1V to 5.5V)**

Logic Low: 500mV nominal (Spec is 800mV max)**

**Note: Artesyn 73-769-001 I²C adapter was used.

Timings

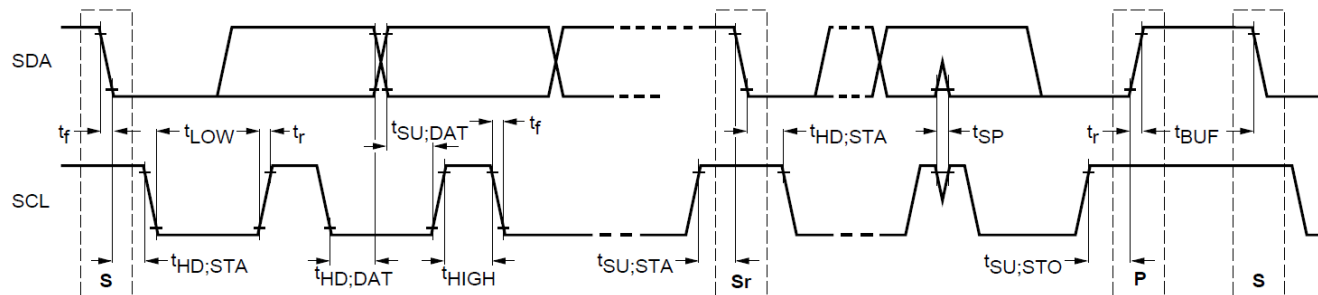

Parameter	Symbol	Standard-Mode Specs		Actual Measured		Unit
		Min	Max			
SCL clock frequency	f_{SCL}	0	100	90.9		KHz
Hold time (repeated) START condition	$t_{HD;STA}$	4.0	-	4.74		μ S
LOW period of SCL clock	t_{LOW}	4.7	-	4.86		μ S
HIGH period of SCL clock	t_{HIGH}	4.0	-	4.84		μ S
Setup time for repeated START condition	$t_{SU;STA}$	4.7	-	4.884		μ S
Data hold time	$t_{HD;DAT}$	0	3.65	0.2416		μ S
Data setup time	$t_{SU;DAT}$	250	-	4887		nS
Rise time	t_r	-	1000	SCL = 669.6	SDA = 710.4	nS
Fall time	t_f	-	300	SCL = 156.8	SDA = 146	nS
Setup time for STOP condition	$t_{SU;STO}$	4.0	-	5.02		μ S
Bus free time between a STOP and START condition	t_{BUF}	4.7	-	95***		μ S

***Note: Artesyn 73-769-001 I²C adapter (USB to I²C) and Universal PMBus™ GUI software was used.

COMMUNICATION BUS DESCRIPTIONS

Device Addressing

The CSU550AP responds to supported commands on the I²C bus that are addressed according to A1 and A0 pins of output connector.

Address pins are held HIGH by default via pulled up to internal 3.3V supply with a 10K ohm resistor. To set the address as “0”, the corresponding address line needs be pulled down to logic ground level. Below tables show the address of the power supply with A0 and A1 pins set to either “0” or “1”.

PSU Slot	Slot ID Bits		PMBus™ Address	EEPROM (FRU) Read Address
	A1	A0		
1	0	0	0xB0	0xA0
2	0	1	0xB2	0xA2
3	1	0	0xB4	0xA4
4	1	1	0xB6*	0xA6*

*Note: Default PMBus™ address when A0 and A1 are left open.

COMMUNICATION BUS DESCRIPTIONS

I²C Clock Synchronization

The CSU550AP series power supply apply clock stretching. An addressed slave power supply hold the clock line (SCL) low after receiving (or sending) a byte, indicating that it is not yet ready to process more data. The system master that is communicating with the power supply will attempt to raise the clock to transfer the next bit, but must verify that the clock line was actually raised. If the power supply is clock stretching, the clock line will still be low (because the connections are open-drain).

The maximum time-out condition for clock stretching for CSU550AP series is 100 milliseconds.

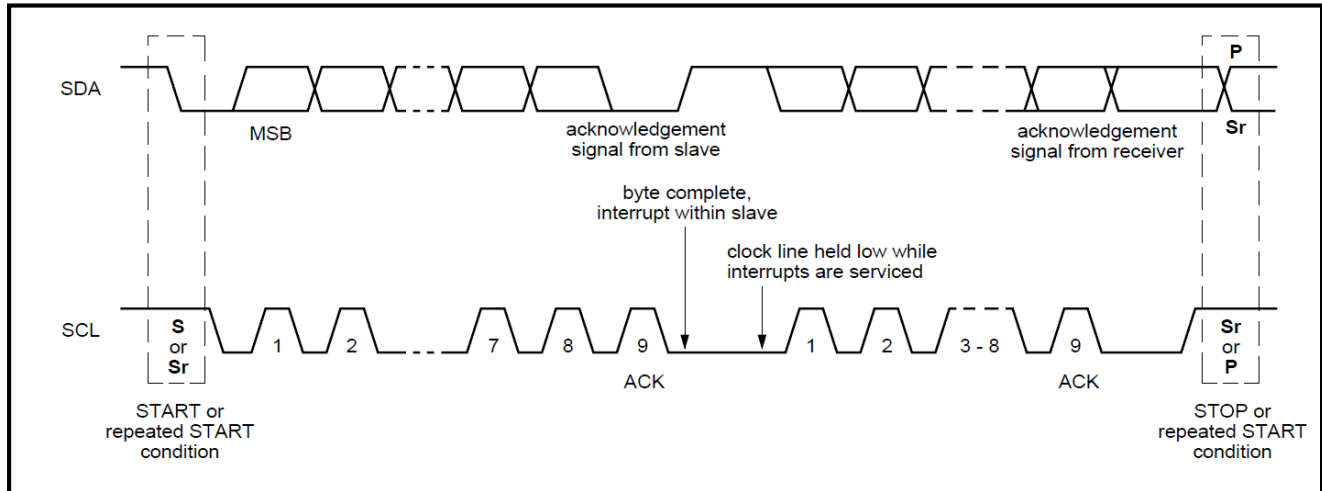

COMMUNICATION BUS DESCRIPTIONS

Cold Redundancy

The CSU550AP series power supply supports capabilities for cold redundancy. This capability helps improve the efficiency and iTHD of the power subsystem when more than one power supply is used in a system. Cold redundancy uses the PMBus™ manufacturer specific command area to define commands for the system to configure the power supplies for cold redundancy.

Overview

A system in 1+1, 2+1, 3+1 or 2+2 redundant mode configuration may not be operated at the optimum efficiency especially when the load is <50% of each power supply's capacity. The cold redundancy mode addresses this condition, where certain power supplies in a system can go into "cold standby" mode, thereby consuming the least amount of power and still be redundant.

Each power supply in this system will have a preprogrammed threshold for output current by which that power supply may determine whether to be actively providing power to the system, or be in cold standby state. A CR_BUS signal that connects all power supplies in the system, also indicates whether it is safe for power supplies in cold redundant mode to enter into cold standby state. The CR_BUS signal prevents power supplies from going into cold standby mode whenever there isn't any active power supply.

The following table shows the state of the power supplies programmed for cold standby mode based on the condition of the CR_BUS signal and the load share bus voltage.

Logic Matrix for Cold Standby Power Supplies:

CR_BUS	Load Share	Cold Standby Power Supply State(s)
High	< VCR_ON	Cold Standby
Low	< VCR_ON	Active
High	> VCR_ON	Active
Low	> VCR_ON	Active

Note: VCR_ON is the voltage threshold set inside the power supplies configured for cold standby which tells them to power down into cold standby state when the load share voltage is less than VCR_ON.

When CR_BUS is asserted (or goes low), all power supplies in the system should go active and immediately provide power to the system.

SMBus Commands for Cold Redundancy

Configuring Cold Redundancy with Cold_Redundancy_Config (D0h)

The PMBus™ manufacturer specific command MFR_SPECIFIC_00 is used to configure the operating state of the power supply related to cold redundancy. This command for Cold_Redundancy_Config is D0h. The table below shows the configuration of the power supply based on the value in the Cold_Redundancy_Config register. PEC is used for read/write of this register.

COMMUNICATION BUS DESCRIPTIONS

Cold Redundancy Configuration Table

Cold_Redundancy_Config (D0h)		
Value	State	Description
00h	Standard Redundancy (Default Power on State)	Turns the power supply into standard redundant load sharing mode. The power supply's CR_BUS signal shall be OPEN but still pull the bus low if a fault occurs.
01h	Cold Redundant Active	Defines this power supply to be the one that is always ON in a cold redundancy configuration.
02h	Cold Standby 1	Defines the power supply that is the first to turn on in a cold redundant configuration as the load increases. This power supply usually has the lowest current threshold.
03h	Cold Standby 2	Defines the power supply that is the second to turn on in a cold redundant configuration as the load increases.
04h	Cold Standby 3	Defines the power supply that is the third to turn on in a cold redundant configuration as the load increases.
05h	Always Cold Standby	Defines this power supply to be always in cold redundant configuration no matter what the load condition. Support for this condition will be limited to 1920W maximum output.
06h-FFh	Reserved	

When the CR_BUS transitions from a high to a low state; each PSU programmed to be in cold standby state shall be put into standard redundancy mode (Cold_Redundancy_Config = 00h). For the power supplies to enter cold redundancy mode the system must re-program the power supplies using the Cold_Redundancy_Config command. All power supplies are pre-programmed for load thresholds on Cold Standby 1, 2, and 3.

Note: Cold Redundancy mode 05h can be supported only up to 80% of the max rated loading.

Cold Redundant Signal (CR_BUS)

There is an additional signal defined supporting Cold Redundancy. This is connected to a bus shared between the power supplies: CR_BUS. This is a tri-state output signal of the power supply used to communicate a fault or Vout under voltage level has occurred in one of the power supplies. This is used to power on all the power supplies in the system via the CR_BUS. When the signal is pulled high, it allows all power supplies in cold standby mode to go into cold standby state when the load share voltage is below the VCR_ON level. When the signal is left open on all power supplies, it forces all cold standby power supplies into the ON. Below is a table showing the logic state of the CR_BUS signal depending upon the programmed configuration of the power supply in D0h, the operating state of the power supply, and the power supply fault status.

COMMUNICATION BUS DESCRIPTIONS

Cold Redundancy State Table

Cold Redundant Config	Operating State	Power Supply Fault Status	CR_Bus#
Active	On	OK	High
Cold Standby 1,2,3	On	OK	Open
Cold Standby 1,2,3	Cold Standby	OK	Open
Active	Off	Fault	Low
Cold Standby 1,2,3	On	Fault	Low
Cold Standby 1,2,3	Cold Standby	Fault	Low

The CR_Status input is based on both the Cold_Redundancy_Config register as well as the fault state of the power supply. The resulting output is a tri-state output. The output is low when there is a fault in any power supply or when cold redundancy is disabled. The output is high only when a power supply is programmed for the cold redundancy active mode and it is functioning OK. The output is open only when the power supply is programmed for cold redundant standby mode and is functioning OK. This means that there needs to be one good power supply programmed for active cold redundant mode to allow power supply to function in cold standby mode; otherwise, all power supplies will power ON and come out of cold redundant mode.

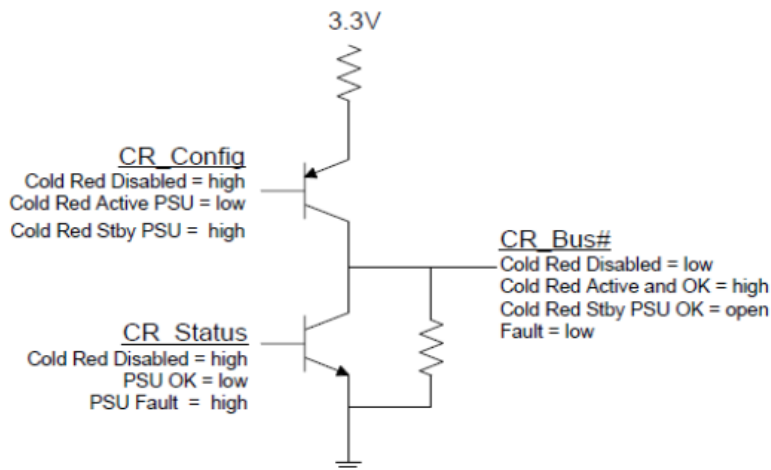

CR_BUS# Functional Diagram

CR_BUS Signal Characteristic

Signal Type	Active: Tri-State Output Cold Standby: Input Signal	
	Min	Max
Logic Level Low (Power Supply ON)	0V	0.4V
Logic Level High (Power Supply OFF)	2.4V	3.46V
Source Current, Cold Amber = High	2mA	-
Sink Current, Cold Amber = Low	400µA	-
Cold Amber Fault Delay	-	10µs
Cold Amber Turn On Delay	-	100µs

COMMUNICATION BUS DESCRIPTIONS

BMC Requirements

The BMC uses the Cold_Redundancy_Config command to configure the power supply's roll in cold redundancy and to enable/disable cold redundancy. It is recommended that the BMC schedules a rolling change for which PSU is the Active, Cold Stby 1, Cold Stby 2, and Cold Stby 3 power supply. This allows for equal loading across power supply over their life.

Black Box

The power supply can store PMBus and other data into non-volatile memory upon a critical failure that caused the power supply to shut down. The data can be accessed via the PMBus interface by applying power to the 12V_{SB} pins. No AC power needs to be applied to the power supply.

Data is saved to the black box for the following fault events:

- General fault
- Over voltage on output
- Over current on output
- Loss of AC input
- Input voltage fault
- Fan failure
- Over temperature

Black Box Process:

- 1) System writes system tracking data to the power supply RAM at power ON.
- 2) System writes the real time clock data to the PSU RAM once every ~5 minutes.
- 3) Power supply tracks the number of PSON and AC power cycles in EEPROM.
- 4) Power supply tracks ON time in EEPROM.
- 5) Power supply loads warning and fault event counter data from EEPROM into RAM.
- 6) Upon a warning event, the PSU will increment the associated counter in RAM.
- 7) Upon and fault event, the PSU will increment the associated counter in RAM.
- 8) Upon a fault event that causes the PSU to shut down, all event data in the PSU's RAM is saved to event data location N in the power supply's EEPROM. This data includes the real time clock, the number of AC & PSON power cycles, PSU ON time, warning event counters and fault event counters.

COMMUNICATION BUS DESCRIPTIONS

Commands:

Name: MFR_BLACKBOX

Format: Read Block with PEC (238 bytes)

Code: DCh

	Item	Number of Bytes	Description
System Tracking Data	System top assembly number	10	The system will write its Intel part number for the system top assembly to the power supply when it is powered ON. This is 9 ASCII characters.
	System serial number	10	The system shall write the system serial number to the power supply when it is powered ON. This include the serial number and date code.
	Motherboard assembly number	10	The system will write the motherboard Intel part number for the assembly to the power supply when it is powered ON. This is 9 ASCII characters.
	Motherboard serial number	10	The system shall write the motherboard's serial number to the power supply when it is powered ON. This includes the serial number and date code.
	Present total PSU ON time	3	Total on time of the power supply with PSON asserted in minutes. LSB = 1 minute
	Present number of AC power cycles	2	Total number of times the power supply powered OFF then back ON due to loss of AC power. This is only counted when the power supply's PSON# signal is asserted. This counter shall stay at FFFFh once the max is reached.
	Present number of PSON power cycles	2	Total number of times the power supply is powered OFF then back ON due to the PSON# signal de-asserting. This is only counted when AC power is present to the power supply. This counter shall stay at FFFFh once the max is reached.
Power supply event data (N)		38	Most recent occurrence of saved black box data
Time Stamp			The power supply shall track these time and power cycle counters in RAM. When the a black box event occurs the data is saved into the Black Box.
	Power supply total power on time	3	Total on time of the power supply in minutes LSB = 1 minute
	Real Time Clock Data from System (reserved for future use)	4	This time stamp does not need to generated by the power supply. The system rights a real time clock value periodically to the power supply using the MFR_REAL_TIME command. Format is based on IPMI 2.0. Time is an unsigned 32-bit value representing the local time as the number of seconds from 00:00:00, January 1, 1970. This format is sufficient to maintain time stamping with 1-second resolution past the year 2100. This is based on a long standing UNIX-based standard for time keeping, which represents time as the number of seconds from 00:00:00, January 1, 1970 GMT. Similar time formats are used in ANSI C
	Number of AC power cycles	2	Number of times the power supply powered OFF then back ON due to loss of AC power at the time of the event. This is only counted when the power supply's PSON# signal is asserted.
	Number of PSON power cycles	2	Number of times the power supply is powered OFF then back ON due to the PSON# signal deasserting at the time of the event. This is only counted when AC power is present to the power supply.

COMMUNICATION BUS DESCRIPTIONS

	Item	Number of Bytes	Description
PMBus			The power supply shall save these PMBus values into the Black Box when a black box event occurs. Fast events may be missed due to the filtering effects of the PMBus sensors
	STATUS_WORD	2	
	STATUS_IOUT	1	
	STATUS_INPUT	1	
	STATUS_TEMPERTATURE	1	
	STATUS_FAN_1_2	1	
	READ_VIN	2	
	READ_IIN	2	
	READ_IOUT	2	
	READ_TEMPERATURE_1	2	
	READ_TEMPERATURE_2	2	
	READ_FAN_SPEED_1	2	
	READ_PIN	2	
	READ_VOUT	2	
Event Counters			The power supply tracks the total number for each of the following events. These value shall be saved to the black box when a black box event occurs. Once a value has reached 15, it shall stay at 15 and not reset.
	AC shutdown due to under voltage on input	Lower ½	The power supply saves a count of these critical events to non-volatile memory each time they occur. The counters will increment each time the associated STATUS bit is asserted.
	Thermal shutdown	Upper ½	
	Over current or over power shutdown on output	Lower ½	
	General failure shutdown	Upper ½	
	Fan failure shutdown	Lower ½	
	Shutdown due to over voltage on output	Upper ½	
	Input voltage warning; no shutdown	Lower ½	The power supply saves into RAM a count of these warning events. Events are count only at the initial assertion of the event/bit. If the event persists without clearing the bit the counter will not be incremented. When the power supply shuts down it will save these warning event counters to non-volatile memory. The counters will increment each time the associated STATUS bit is asserted.
	Thermal warning; no shutdown	Upper ½	
	Output current power warning; no shutdown	Lower ½	
	Fan slow warning; no shutdown	Upper ½	
	Power supply event data (N-1)	38	
	Power supply event data (N-2)	38	
	Power supply event data (N-3)	38	
	Power supply event data (N-4)	38	

COMMUNICATION BUS DESCRIPTIONS

Name: MFR_REAL_TIME_BLACK_BOX

Format: Write/Read Block with PEC (4 bytes)

Code: DDh

The system shall use this command to periodically write the real time clock data to the power supply.

Format is based on IPMI 2.0. Time is an unsigned 32-bit value representing the local time as the number of seconds from 00:00:00, January 1, 1970. This format is sufficient to maintain time stamping with 1-second resolution past the year 2100.

This is based on a long standing UNIXbased standard for time keeping, which represents time as the number of seconds from 00:00:00, January 1, 1970 GMT. Similar time formats are used in ANSI C.

Name: MFR_SYSTEM_BLACK_BOX

Format: Write/Read Block with PEC (40 bytes). Low byte first.

Code: DEh

The system uses this command to write the following data to the PSU.

Item	Bytes	
System top assembly number	1–10	Low bytes
System serial number	11–20	
Motherboard assembly number	21–30	
Motherboard serial number	31–40	High bytes

Name: MFR_BLACKBOX_CONFIG

Format: Read/Write Byte with PEC

Code: DFh

Bit	Value	Description
0	0 = disable black box function 1 = enable black box function	Writing a '1' enables the power supply with black box function. Writing a '0' disables the power supply black box function. The state of MFR_BLACKBOX_CONFIG will be saved in non-volatile memory so that it is not lost during power cycling. Intel will receive the power supply with the black box function enabled; bit 0 = '1'.

Name: MFR_CLEAR_BLACKBOX

Format: Send Byte with PEC

Code: E0h

The MFR_CLEAR_BLACKBOX command is used to clear all black box records simultaneously. This command is write only. There is no data byte for this command.

COMMUNICATION BUS DESCRIPTIONS

Name: MFR_HW_COMPATIBILITY

Format: Read Word

Code: D4h

Bytes	Value	Description
Low	ASCI code for first letter/number of the PSU HW compatibility.	This is a COMPATIBILITY value used to tell if there are any changes in the FW that create an incompatibility with the FW. This value only changes when the PSU HW is changed creating an incompatibility with older versions of FW.
High	ASCI code for second letter/number of the PSU HW compatibility	

Name: MFR_FWUPLOAD_CAPABILITY

Format: Read Byte

Code: D5h

The system can read the power supply's FW upload mode capability using this command. For any given power supply; more than one FW upload mode may be supported. The supported FW upload mode(s) must support updating all available FW in the power supply.

Bit	Value	Description
0 (for future use)	1 = PSU support FW uploading in standby mode only	For future use
1 (for future use)	1 = PSU supports FW uploading in ON state; but all the new FW will not take effect until a power cycle with PSON.	For future use
2	1 = PSU supports FW uploading in the ON state and no power cycle needed	Method used for updating the application program in the power supply
3-7	Reserved	

COMMUNICATION BUS DESCRIPTIONS

Name: MFR_FWUPLOAD_STATUS

Format: Read/Write Byte

Code: D6h

Bytes	Value	Description
0	0 = exit firmware upload mode 1 = firmware upload mode	Writing a 1 puts the power supply into firmware upload mode and gets it ready to receive the 1st image block via the MFR_FW_UPLOAD command. The system can use this command at any time to restart sending the FW image. Writing a 0 puts the power supply back into normal operating mode. Writing a 1 restarts This command will put the PSU into standby mode if the PSU supports FW update in standby mode only. If the power supply image passed to the PSU is corrupt the power supply will stay in firmware upload mode even if the system requested the PSU to exit the FW upload mode
1-7		Reserved

Name: MFR_FW_REVISION

Format: Block Write (block = size as defined by the image header)

Code: D7h

Bytes	Value	Description
Block size defined in header	Image header & image data	Command used to send each block of the FW image. The image contains block sequencing numbers to make sure the PSU puts the right data blocks into the right memory space on the PSU MCU.

COMMUNICATION BUS DESCRIPTIONS

Name: MFR_FWUPLOAD_STATUS

Format: Read Word

Code: D8h

At any time during or after the firmware image upload the system can read this command to determine status of the firmware upload process.

Reset: all bits get reset to '0' when the power supply enters FW upload mode.

Bit	Description
0	1 = Full image received successful
1	1 = Full image not received yet. The PSU will keep this bit asserted until the full image is received by the PSU.
2	1 = Full image received but image is bad or corrupt. Power supply can power ON, but only in 'safe mode' with minimal operating capability.
3 (for future use)	1 = Full image received but image is bad or corrupt. Power supply can power ON and support full features.
4	1 = FW image not supported by PSU. If the PSU receives the image header and determines that the PSU HW does not support the image being sent by the system; it shall not accept the image and it shall assert this bit.
5-15	Reserved

Name: MFR_FW_REVISION

Format: Block Read, 3 bytes

Code: D9h

Bytes	Value	Description
0	0 – 255	Minor revision; secondary
1	0 – 255	Minor revision; primary
2	0 – 255	Bit 7: 1-> Down grading of PSU FW has to be avoided. System BMC can elect to ignore this bit if needed, but recommended to follow. 0 -> No restriction in downgrading the PSU FW. BMC can update the PSU FW to be in sync with its known version. Bit 0-6: Major revision

COMMUNICATION BUS DESCRIPTIONS

FRU (EEPROM) Data

The FRU (Field Replaceable Unit) data format is compliant with the Intel IPMI v1.0 specification.

The CSU550AP-3 uses 1 page of EEPROM for FRU purpose. A page of EEPROM contains up to 256 byte-sized data locations.

Where:	OFFSET	-The OFFSET denotes the address in decimal format of a particular data byte within CSU550AP-3 EEPROM.
	VALUE	-The VALUE details data written to a particular memory location of the EEPROM.
	DEFINITION	-The contents DEFINITION refers to the definition of a particular data byte.

CSU550AP series FRU (EEPROM) Data:

OFFSET		DEFINITION (REMARKS)	SPEC VALUE	
(DEC)	(HEX)		(DEC)	(HEX)
COMMON HEADER, 8 BYTES				
0	00	FORMAT VERSION NUMBER (Common Header) 7:4 - Reserved, write as 0000b 3:0 - Format Version Number = 1h for this specification	1	01
1	01	INTERNAL USE AREA OFFSET (Not required, do not reserve)	0	00
2	02	CHASSIS INFO AREA OFFSET (Not required, do not reserve)	0	00
3	03	BOARD INFO AREA OFFSET (Not required, do not reserve)	0	00
4	04	PRODUCT INFO AREA OFFSET	1	01
5	05	MULTI RECORD AREA OFFSET	9	09
6	06	PAD (Not required, do not reserve)	0	00
7	07	ZERO CHECK SUM (256 - (Sum of bytes 0 to 6))	245	F5
PRODUCT INFORMATION AREA, 64 BYTES				
8	08	FORMAT VERSION NUMBER (Product Info Area) 7:4 - Reserved, write as 0000b 3:0 - Format Version Number = 1h for this specification	1	01
9	09	PRODUCT INFO AREA LENGTH (In multiples of 8 bytes)	9	09
10	0A	Language (English)	25	19
11	0B	MANUFACTURER NAME Type/Length (C7H) 7:6 - (11)b, 8-bit ASCII + Latin 1, 5:0 - (000111)b, 7-byte Allocation	199	C7
12	0C	MANUFACTURER'S NAME 7 bytes sequence "A" = 41h "R" = 52h "T" = 54h "E" = 45h "S" = 53h "Y" = 59h "N" = 4Eh	65	41
13	0D		82	52
14	0E		84	54
15	0F		69	45
16	10		83	53
17	11		89	59
18	12		78	4E
19	13	PRODUCT NAME Type/Length (D0H) Type = "ASCII+Latin 1" = (11)b Length = 16 bytes = (010000)b	208	D0

COMMUNICATION BUS DESCRIPTIONS

CSU550AP-3 FRU (EEPROM) Data:

OFFSET		DEFINITION (REMARKS)	SPEC VALUE	
(DEC)	(HEX)		(DEC)	(HEX)
20	14	Product Name, 8 Byte sequence "CRPS550W" In Decimal = 067d, 082d, 080d, 083d, 053d, 053d, 048d, 087d, 32d, 32d, 32d, 32d, 32d, 32d, 32d, 32d In Hex = 43H, 52H, 50H, 53H, 35H, 35H, 30H, 57H, 20H, 20H, 20H, 20H, 20H, 20H, 20H, 20H	67	43
21	15		82	52
22	16		80	50
23	17		83	53
24	18		53	35
25	19		53	35
26	1A		48	30
27	1B		87	57
28	1C		32	20
29	1D		32	20
30	1E		32	20
31	1F		32	20
32	20		32	20
33	21		32	20
34	22		32	20
35	23	32	20	
36	24	PRODUCT PART/MODEL NUMBER Type/Length (D0H) Type = "ASCII+LATIN1" = (11)b Length = 16 Bytes = (010000)b	208	D0
37	25	Part / Model Number "CSU550AP-3" In Decimal = 067d, 083d, 085d, 053d, 053d, 048d, 065d, 080d, 045d, 051d In Hex = 43H, 53H, 55H, 35H, 35H, 30H, 41H, 50H, 2DH, 33H Note: For Inspur version, the model is "CSU550AP-3-100".	67	43
38	26		83	53
39	27		85	55
40	28		53	35
41	29		53	35
42	2A		48	30
43	2B		65	41
44	2C		80	50
45	2D		45	2D
46	2E		51	33
47	2F		32	20
48	30		32	20
49	31		32	20
50	32		32	20
51	33		32	20
52	34	PRODUCT VERSION NUMBER Type/Length (C2h) Type = "ASCII+LATIN1" = (11)b Length = 2 bytes = (000010)b	194	C2
53	35	Version, 2 Byte sequence "XX"	XX	XX
54	36		XX	XX
55	37	PRODUCT SERIAL NUMBER Type/Length Type = "ASCII+LATIN1" = (11)b Length = 13 bytes = (001101)b	205	CD
56	38	Serial number, 13 Byte sequence "XXXXXXXXXXXXX"	XX	XX
57	39		XX	XX
58	3A		XX	XX
59	3B		XX	XX
60	3C		XX	XX
61	3D		XX	XX
62	3E		XX	XX
63	3F		XX	XX
64	40		XX	XX
65	41		XX	XX
66	42		XX	XX
67	43		XX	XX
68	44		XX	XX

COMMUNICATION BUS DESCRIPTIONS

CSU550AP-3 FRU (EEPROM) Data:

OFFSET		DEFINITION (REMARKS)	SPEC VALUE	
(DEC)	(HEX)		(DEC)	(HEX)
69	45	PAD (reserved) Default value is 0.	0	00
70	46		0	00
71	47	ZERO CHECK SUM (256-(sum of bytes 8 to 70)) Per Unit Zero Check Sum :Should follow check sum calculation as per IPMI v1.3 specs	92	5C
Multi Record Area, 56 Bytes				
Power Supply Record Header				
72	48	Record Type = 00 for power supply info	0	00
73	49	End of List /Record Format Version Number for 12V Output Record	2	02
74	4A	Record Length of 12V Output Record	20	14
75	4B	Record checksum	172	AC
76	4C	header checksum	62	3E
Power Supply Record				
Combined Wattage ,Byte 1 and Byte 2: 550W = 0226H				
77	4D	byte 1 (LSB) = 26h = 38d	38	26
78	4E	byte 2 (MSB) =02h = 02d 2 Bytes Sequence In Decimal = 38d, 02d In Hex = 26h,02h		
79	4F	Peak VA , 1500W = 05DCH	220	DC
80	50	2 Bytes Sequence In Decimal = 220d, 5d In Hex = DCH, 05H		
81	51	Inrush Current , 10A In Decimal = 10d In Hex = 0AH	10	0A
82	52	Inrush Interval , 5mS In Decimal = 5d In Hex = 05H	5	05
Low End Input Voltage Range 1(10mV) , (90V / 10mV) 9000 = 2328H				
83	53	2 Bytes Sequence In Decimal = 40d, 35d	40	28
84	54	In Hex = 28H, 23H	35	23
High End Input Voltage Range 1(10mV) , (264V/10mV) 26400= 6720H				
85	55	2 Bytes Sequence In Decimal = 032d, 103d	32	20
86	56	In Hex = 20H, 67H	103	67
87	57	Low End Input Frequency Range , 47Hz = 2FH	47	2F
88	58	Low End Input Frequency Range , 63Hz = 3FH	63	3F
89	59	AC Dropout Tolerance in ms , 10mS= 0AH	10	0A
90	5A	Binary Flags: For each of the following binary flags No = 0, Yes = 1; Bits 7-5: RESERVED, WRITE AS 000B Bit4: Tachometer Pulses Per Rotation / Predictive Fail Polarity BIT = 0 Bit3: Hot Swap / Redundancy Support BIT = 1 Bit2: Auto switch Support BIT = 1 Bit1: Power Factor Correction Support BIT = 1 Bit0: Predictive Fail Support BIT = 0	14	0E
Peak Wattage Capacity and Holdup Time ,(Set for 650Watts/3S)				
91	5B	In Decimal = 138 In Hex = 8AH (LSB First)	138	8A
92	5C	In Decimal = 50 In Hex = 32H	50	32

COMMUNICATION BUS DESCRIPTIONS

CSU550AP-3 FRU (EEPROM) Data:

OFFSET		DEFINITION (REMARKS)	SPEC VALUE	
(DEC)	(HEX)		(DEC)	(HEX)
93	5D	Combined Wattage, Byte 1: 0000 0000 =00H = 00d (12VMain - voltage1,12VSB - voltage2) Byte 2 and Byte 3: Total combined Wattage = 550W => 0226H(LSB First)	0	00
94	5E		38	26
95	5F		2	02
96	60	Predictive Fail Tachometer Lower Threshold, Not Applicable. Predictive Failure is not Supported.	0	00
12V OUTPUT RECORD HEADER				
97	61	Record Type = 01 for power supply info	1	01
98	62	End of List /Record Format Version Number for 12V Output Record	2	02
99	63	Record Length of 12V Output Record	13	0D
100	64	Record checksum (256-(sum of bytes 102 to 114))	244	F4
101	65	header checksum (256-(sum of bytes 97 to 100))	252	FC
12V OUTPUT RECORD				
102	66	Output Information, 001 = 01H Bit 7: Standby Information = 0B Bits 6-4: Reserved, Write as 000B Bits 3-0: Output Number 1 = 001B	1	01
103	67	Nominal Voltage (10mV), (12V / 10mV) 1200 = 04B0H 2 Bytes Sequence In Decimal: 176d, 004d In Hex: B0H, 04H	176	B0
104	68		4	04
105	69	Maximum Negative Voltage Deviation (10mV), 1140 = 0474H 2 Bytes Sequence In Decimal: 116d, 004d In Hex: 74H, 04H	116	74
106	6A		4	04
107	6B	Maximum Positive Voltage Deviation (10mV), 1260 =04ECH 2 Bytes Sequence In Decimal: 236d, 004d In Hex: ECH, 04H	236	EC
108	6C		4	04
109	6D	Ripple and Noise pk-pk (mV), 120 = 78H 2 Bytes Sequence In Decimal: 120d, 000d In Hex: 78H, 00H	120	78
110	6E		0	00
111	6F	Minimum Current Draw (mA), 0000 = 0000H 2 Bytes Sequence In Decimal: 000d, 000d In Hex: 00H, 00H	0	00
112	70		0	00
113	71	Maximum Current Draw (mA), 45000 = AFC8H 2 Bytes Sequence In Decimal: 200d, 175d In Hex: C8H, AFH	200	C8
114	72		175	AF
12VSB OUTPUT RECORD HEADER				
115	73	Record type = 01 for DC Output Record	1	01
116	74	End of List /Record Format Version Number for 12VSB Output Record	130	82
117	75	Record Length of 12V DC Output Record	13	0D
118	76	Record CHECKSUM of 12VSB Output Record	29	1D
119	77	Header CHECKSUM of 12VSB Output Record Header	83	53

COMMUNICATION BUS DESCRIPTIONS

CSU550AP-3 FRU (EEPROM) Data:

OFFSET		DEFINITION (REMARKS)	SPEC VALUE	
(DEC)	(HEX)		(DEC)	(HEX)
120	78	Output Information, 002 = 02H Bit 7: Standby Information = 1B Bits 6-4: Reserved, Write as 000B Bits 3-0: Output Number 2 = 0010B	130	82
121 122	79 7A	Nominal Voltage (10mV), (12V / 10mV) 1200 = 04B0H 2 Bytes Sequence In Decimal: 176d, 004d In Hex: B0H, 04H	176 4	B0 04
123 124	7B 7C	Maximum Negative Voltage Deviation (10mV), 1140 = 0474H 2 Bytes Sequence In Decimal: 116d, 004d In Hex: 74H, 04H	116 04	74 04
125 126	7D 7E	Maximum Positive Voltage Deviation (10mV), 1260 = 04ECH 2 Bytes Sequence In Decimal: 236d, 004d In Hex: ECH, 04H	236 4	EC 04
127 128	7F 80	Ripple and Noise pk-pk (mV), 120 = 78H 2 Bytes Sequence In Decimal: 120d, 000d In Hex: 78H, 00H	120 0	78 00
129 130	81 82	Minimum Current Draw (10mA), 0000 = 0000H 2 Bytes Sequence In Decimal: 000d, 000d In Hex: 00H, 00H	0 0	00 00
131 132 133 134 135	83 84 85 86 87	Maximum Current Draw (10mA), 2500 = 09C4H 2 Bytes Sequence In Decimal: 196d, 09d In Hex: C4H, 09H Reserved, Default value is 0. Reserved, Default value is 0. Reserved, Default value is 0.	196 09 0 0 0	C4 09 00 00 00
136 137 138 139 140 141 142 143 144 145 146 147 148 149 150 151 152 153 154 155 156 157	88 89 8A 8B 8C 8D 8E 8F 90 91 92 93 94 95 96 97 98 99 9A 9B 9C 9D	(88h-FFh is Reserved, Default value is 0.)	0 0	00 00

COMMUNICATION BUS DESCRIPTIONS

CSU550AP-3 FRU (EEPROM) Data:

OFFSET		DEFINITION (REMARKS)	SPEC VALUE	
(DEC)	(HEX)		(DEC)	(HEX)
158	9E	(88h-FFh is Reserved, Default value is 0.)	0	00
159	9F		0	00
160	A0		0	00
161	A1		0	00
162	A2		0	00
163	A3		0	00
164	A4		0	00
165	A5		0	00
166	A6		0	00
167	A7		0	00
168	A8		0	00
169	A9		0	00
170	AA		0	00
171	AB		0	00
172	AC		0	00
173	AD		0	00
174	AE		0	00
175	AF	0	00	
176	B0	0	00	
177	B1	(88h-FFh is Reserved, Default value is 0.)	0	00
178	B2		0	00
179	B3		0	00
180	B4		0	00
181	B5		0	00
182	B6		0	00
183	B7		0	00
184	B8		0	00
185	B9		0	00
186	BA		0	00
187	BB		0	00
188	BC		0	00
189	BD		0	00
190	BE		0	00
191	BF		0	00
192	C0		0	00
193	C1		0	00
194	C2		0	00
195	C3		0	00
196	C4		0	00
197	C5		0	00
198	C6		0	00
199	C7		0	00
200	C8		0	00
201	C9		0	00
202	CA		0	00
203	CB		0	00
204	CC		0	00
205	CD		0	00
206	CE		0	00
207	CF		0	00
208	D0		0	00
209	D1		0	00
210	D2		0	00
211	D3		0	00
212	D4	0	00	

COMMUNICATION BUS DESCRIPTIONS

CSU550AP-3 FRU (EEPROM) Data:

OFFSET		DEFINITION (REMARKS)	SPEC VALUE	
(DEC)	(HEX)		(DEC)	(HEX)
213	D5	(88h-FFh is Reserved, Default value is 0.)	0	00
214	D6		0	00
215	D7		0	00
216	D8		0	00
217	D9		0	00
218	DA		0	00
219	DB		0	00
220	DC		0	00
221	DD		0	00
222	DE		0	00
223	DF		0	00
224	E0		0	00
225	E1		0	00
226	E2		0	00
227	E3		0	00
228	E4		0	00
229	E5		0	00
230	E6	0	00	
231	E7	0	00	
232	E8	0	00	
233	E9	0	00	
234	EA	0	00	
235	EB	0	00	
236	EC	0	00	
237	ED	0	00	
238	EE	(88h-FFh is Reserved, Default value is 0.)	0	00
239	EF		0	00
240	F0		0	00
241	F1		0	00
242	F2		0	00
243	F3		0	00
244	F4		0	00
245	F5		0	00
246	F6		0	00
247	F7		0	00
248	F8		0	00
249	F9		0	00
250	FA		0	00
251	FB		0	00
252	FC		0	00
253	FD		0	00
254	FE		0	00
255	FF		0	00

PMBUS™ SPECIFICATIONS

The CSU550AP series is compliant with the industry standard PMBus™ protocol for monitoring and control of the power supply via the I²C interface port.

CSU550AP PMBus™ General Instructions

Equipment Setup

The following is typical I²C communication setup:

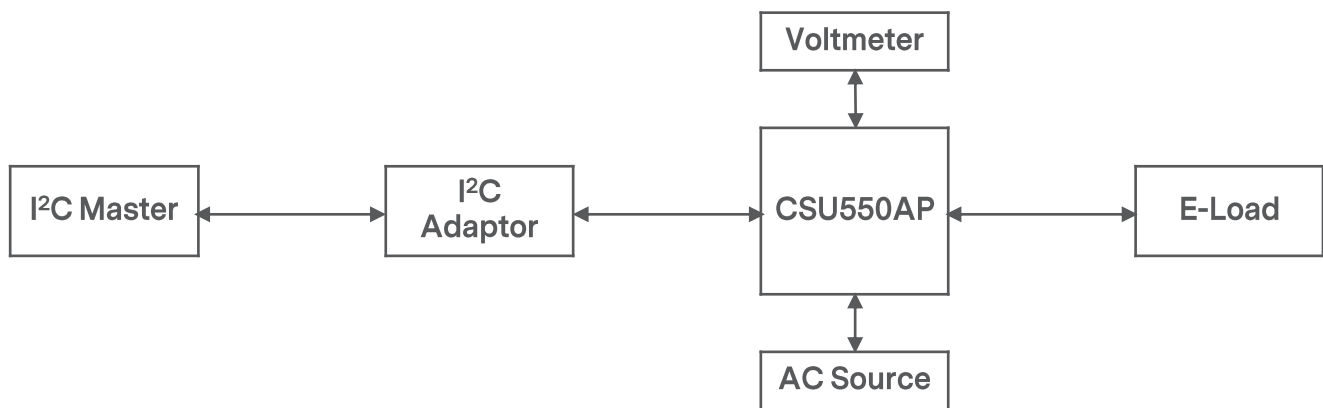

PMBUS™ SPECIFICATIONS

The CSU550AP Supported PMBus™ Command List:

Command Code	Command Name	Default Value	Access Type	Data Bytes	Data Format	Description
00h	Page	0	R	1	Hex	Valid input: 00h
01h	OPERATION	00	R/W	1	Bitmapped	Used to turn the unit ON/OFF in conjunction with the input PSON pin.
	b7:6	10				When PSON = High 00 - Immediate Turn OFF (No Sequencing) 01 - Soft Turn OFF (With Sequencing) 10 - PSU ON
	b5:4	00				Reserved
	b3:2	00				Reserved
	b1:0	00				Reserved
02h	ON_OFF_CONFIG	1D	R/W	1	Bitmapped	The ON_OFF_CONFIG command configures the combination of CONTROL pin input and serial bus commands needed to turn the unit on and off.
03h	CLEAR_FAULTS	0	S		N/A	Send byte w/PEC
05h	PAGE_PLUS_WRITE		W		N/A	Block Write w/PEC Used with STAATUS_INPUT,STATUS_TEMPERATURE,STATUS_IOUT
06h	PAGE_PLUS_READ		R		N/A	Block Write Block Read Process Call w/PEC Used with STATUS_INPUT, STATUS_TEMPERATURE, STATUS_IOUT, STATUS_WORD
19h	CAPABILITY	90	R	1	Bitmapped	Provides a way for the hosts system to determine some key capabilities of a PMBus™ device.
	b7 - Packet Error Checking	1				0 - PEC not supported 1 - PEC supported
	B6:5 - Maximum Bus Speed	00				00 - Maximum supported bus speed, 100KHz 01 - Maximum supported bus speed, 400KHz
	b4 - SMBALERT#	1				0 - SMBus Alert Pin not supported 1 - SMBus Alert Pin supported
	b3 - Numeric Format	0				0 - Linear11, Ulinear16, Slinear16, or Direct 1 - IEEE Half Precision Floating Point Format
	b2 - AVSBus	0				0 - AVSBus not supported 1 - AVSBus supported
	b1:0	00				Reserved
1Ah	QUERY	-	BR/BW		N/A	Used to determine if the PSU supports a specific command; It should return the proper information about any commands listed.

PMBUS™ SPECIFICATIONS

The CSU550AP-3 Supported PMBus™ Command List:

Command Code	Command Name	Default Value	Access Type	Data Bytes	Data Format	Description
1Bh	SMBALERT_MASK	-	BR/BW		N/A	Default masks per Intel spec: Page 00: STATUS_VOUT = FFh STATUS_IOUT = FFh STATUS_INPUT = FFh STATUS_TEMP = FFh STATUS_CML = FFh Page 01: STATUS_VOUT = FFh STATUS_IOUT = DFh STATUS_INPUT = EFh STATUS_TEMP = BFh STATUS_CML = FFh Non-paged: STATUS_FANS_1_2 = FFh
20h	VOUT_MODE	0x17	R	1	Bitmapped	Specifies the mode and parameters of output voltage related data formats.
30h	COEFFICIENTS		BR/BW	5	Hex	Use to retrieve the m, b and R coefficients, needed for DIRECT data format.
	byte 5					R byte
	byte 4:3					b low Byte, b high byte
	byte 2:1					M low Byte, m high byte
3Ah	FAN_CONFIG_1_2	90	R/W	1	Bitmapped	
	b7	1				0 - No fan is installed in position 1 1 - Fan is installed in position 1
	b6	0				1 - Fan is commanded in RPM 0 - Fan is commanded in Duty cycle
	b5:4	01				00 - 1 pulse per revolution 01 - 2 pulse per revolution 10 - 3 pulse per revolution 11 - 4 pulse per revolution
	b3:0					Reserved
3Bh	FAN_COMMAND_1	0000	R/W	2	Linear	Adjusts the operation of the Fans. The device may override the command, if it requires higher value, to maintain proper device temperature. Duty cycle control - commands speeds from 0 to 100%
46h	IOUT_OC_FAULT_LIMIT	E9D8	R	2	Linear	Sets the over-current threshold in Amps. (59.00A)
4Ah	IOUT_OC_WARNING_LIMIT	E998	R	2	Linear	Sets the over-current warning threshold in Amps. (51.00A)
51h	OT_WARN_LIMIT (Hot Spot)	005A	R	2	Linear	Secondary ambient temperature warning threshold, in degree C. Operating limit. (90 degC)
5Dh	IIN_OC_WARN_LIMIT	CAC0	R	2	Linear	Sets the over-current threshold in Amps. (5A)

PMBUS™ SPECIFICATIONS

The CSU550AP-3 Supported PMBus™ Command List:

Command Code	Command Name	Default Value	Access Type	Data Bytes	Data Format	Description
6Ah	POUT_OP_WARN_LIMIT	028A	R	2	Linear	Sets the over power threshold in Watt. (650W)
6Bh	PIN_OP_WARN_LIMIT	0384	R	2	Linear	Sets the over power threshold in Watt. (900W)
78h	STATUS_BYTE		R	1	Bitmapped	Returns the summary of critical faults.
	b7					Reserved
	b6 - OFF					Unit is OFF.
	b5 - VOUT_OV					Output over-voltage fault has occurred.
	b4 - IOUT_OC					Output over-current fault has occurred.
	b3 - VIN_UV					An input under-voltage fault has occurred.
	b2 - TEMPERATURE					A temperature fault or warning has occurred.
	b1 - CML					A communication, memory or logic fault has occurred.
b0					Reserved	
79h	STATUS_WORD		R	2	Bitmapped	Summary of units fault and warning status.
	b15 - VOUT					An output voltage fault or warning has occurred.
	b14 - IOUT					An output current or power fault or warning has occurred.
	b13 - INPUT					An input voltage, current or power fault or warning as occurred.
	b12					Reserved
	b11 - POWER_GOOD#					The POWER_GOOD signal is de-asserted.
	b10 - FANS					A fan or airflow fault or warning has occurred.
	b9:8					Reserved
	b7 - BUSY					A fault was declared because the device was busy and unable to respond.
	b6 - OFF					Unit is OFF.
	b5 - VOUT_OV					Output over-voltage fault has occurred.
	b4 - IOUT_OC					Output over-current fault has occurred.
	b3 - VIN_UV					An input under-voltage fault has occurred.
	b2 - TEMPERATURE					A temperature fault or warning has occurred.
b1 - CML					A communication, memory or logic fault has occurred.	
b0					Reserved	

PMBUS™ SPECIFICATIONS

The CSU550AP-3 Supported PMBus™ Command List:

Command Code	Command Name	Default Value	Access Type	Data Bytes	Data Format	Description
7Ah	STATUS_VOUT		R	1	Bitmapped	
	b7 - VOUT Over-Voltage Fault					VOUT over-voltage fault
	b6:5					Reserved
	b4 - VOUT Under-Voltage Fault					VOUT under-voltage fault
	b3:0					Reserved
7Bh	STATUS_IOUT		R	1	Bitmapped	
	b7 - IOUT Overcurrent Fault					IOUT over-current fault
	b6					Reserved
	b5 - IOUT Overcurrent Warning					IOUT over current warning
	b4:2					Reserved
	b1 - POUT_OP_FAULT					POUT_OP_FAULT
	b0 - POUT_OP_WARNING					POUT_OP_WARNING
7Ch	STATUS_INPUT		R	1	Bitmapped	Input related faults and warnings
	b7 - VIN_OV_FAULT					VIN over-voltage fault
	b6					Reserved
	b5 - VIN_UV_WARNING					VIN under-voltage warning
	b4 - VIN_UV_FAULT					VIN under-voltage fault
	b3 - Unit Off For Low Input Voltage					Unit is OFF for insufficient input voltage.
	b2					Reserved
	b1 - IIN_OC_WARNING					IIN over-current warning
	b0 - PIN_OP_WARNING					PIN over power warning
7Dh	STATUS_TEMPERATURE		R	1	Bitmapped	Temperature related faults and warnings
	b7 - Over Temperature Fault					Over temperature Fault
	b6 - Over Temperature Warning					Over temperature Warning
	b5:0					Reserved
7Eh	STATUS_CML		R	1	Bitmapped	Communications, Logic and Memory
	b7 - Invalid/Unsupported command					Invalid or unsupported command received
	b6 - Invalid/Unsupported Data					Invalid data
	b5 - Packet Error Check Failed					Packet Error Check Failed
	b4:0					Reserved
80h	INPUT_TYPE		R	1	Hex	00h - no input 01h - AC input 02h - DC input

PMBUS™ SPECIFICATIONS

The CSU550AP-3 Supported PMBus™ Command List:

Command Code	Command Name	Default Value	Access Type	Data Bytes	Data Format	Description
81h	STATUS_FANS_1_2		R	1	Bitmapped	
	b7 - Fan1 Fault					Fan1 fault
	b6					Reserved
	b5- Fan1 Warning					Fan1 warning
	b4					Reserved
	b3 - Fan1 Speed Overridden					Fan1 speed overridden
	b2:0					Reserved
86h	Ein		BR	6	Direct	Returns the accumulated input power over time.
87h	Eout		BR	6	Direct	Returns the accumulated output power over time.
88h	READ_VIN		R	2	Linear	Returns input voltage in Volts AC.
89h	READ_IIN		R	2	Linear	Returns input current in Amps.
8Bh	READ_VOUT		R	2	Linear	Returns the actual, measured voltage in Volts.
8Ch	READ_IOUT		R	2	Linear	Returns the output current in Amps.
8Dh	READ_TEMPERATURE_1 (Ambient)		R	2	Linear	Returns the temperature of temperature test 1.
8Eh	READ_TEMPERATURE_2 (Hot Spot)		R	2	Linear	Returns the temperature of temperature test 2.
90h	READ_FAN_SPEED_1		R	2	Linear	Speed of Fan 1
96h	READ_POOUT		R	2	Linear	Returns the output power, in Watts.
97h	READ_PIN		R	2	Linear	Returns the input power, in Watts.
98h	PMBUS_Revision	22	R	1	Bitmapped	Reads the PMBus revision number.
	b7:5	0010				Part 1 Revision 0000 - Revision 1.0 0001 - Revision 1.1 0010 - Revision 1.2
	b4:0	0010				Part 2 Revision 0000 - Revision 1.0 0001 - Revision 1.1 0010 - Revision 1.2
99h	MFR_ID	ARTESYN#### #### (0x41 52 54 45 53 59 4E 23 23 23 23 23 23 23 23)	BR	15	ASCII	Abbrev or symbol of manufacturers name. ASCII
9Ah	MFR_MODEL	CSU550AP- 3##### (0x43 53 55 35 35 30 41 50 2D 33 23 23 23 23 23)	BR	15	ASCII	Manufacturers model number, ASCII format
9Bh	MFR_REVISION	00.01.09.00.01.0 1	BR	6	Hex	1 st byte and 4 th byte is 0x00. 2 nd and 3 rd byte: Secondary major and minor revision. 5 th and 6 th byre: Primary major and minor revision.

PMBUS™ SPECIFICATIONS

The CSU550AP-3 Supported PMBus™ Command List:

Command Code	Command Name	Default Value	Access Type	Data Bytes	Data Format	Description
9Ch	MFR_LOCATION	LUODING (0x4C 55 4F 44 49 4E 47)	BR	7	ASCII	Manufacturers facility, ASCII format
9Dh	MFR_DATE	0716 (0x30 37 31 36)	BR	4	ASCII	Manufacture date, ASCII format structure : MMY
9Eh	MFR_SERIAL	“xxxxxxxxxxxx xxxxx”	BR	15	ASCII	Unit serial number, ASCII format.
A0h	MFR_VIN_MIN	005A	R	2	Linear	Minimum input voltage (90Vac)
A1h	MFR_VIN_MAX	0108	R	2	Linear	Maximum input voltage (264Vac)
A2h	MFR_IIN_MAX		R	2	Linear	Maximum input current (4A)
A4h	MFR_VOUT_MIN	16CD	R	2	Linear	Minimum output voltage regulation window (11.4V)
A5h	MFR_VOUT_MAX	1933	R	2	Linear	Maximum output voltage regulation window (12.6V)
A6h	MFR_IOUT_MAX	E968	R	2	Linear	Maximum output Current (45A)
A7h	MFR_POUT_MAX	0226	R	2	Linear	Maximum Output Power (550W)
A8h	MFR_TAMBIENT_MAX	55	R	2	Linear	Maximum operation temperature (55deg)
A9h	MFR_TAMBIENT_MIN	0	R	2	Linear	Minimum ambient temperature (0deg)
C0h	MFR_MAX_TEMP_1 (Ambient)	0046	R	2	Linear	Maximum ambient temperature (70degC)
C1h	MFR_MAX_TEMP_2 (hot spot)	0069	R	2	Linear	Maximum hot spot temperature (105degC)
D0h	Cold_Redundancy_Config	00	R/W	1	Hex	00 - Normal 01 - Active 02 - Cold Standby 1 03 - Cold Standby 2 04 - Cold Standby 3 05 - Always Cold Standby
D7h	MFR_FWUPLOAD		BW			
D8h	MFR_FWUPLOAD_STATUS		R	2		
D9h	MFR_FW_REVISION	09.01.01	BR	3		Firmware reversion: SEC_Minor, PRI_Minor, FW_Major
DCh	MFR_BLACKBOX		BR	238		
DDh	MFR_REAL_TIME_BLACK_B OX		BR/BW	4		
DEh	MFR_SYSTEM_BLACK_BOX		BR/BW	40		
DFh	MFR_BLACKBOX_CONFIG		R/W			
E0h	MFR_CLEAR_BLACKBOX		W			

PMBUS™ SPECIFICATIONS

Firmware Update Process

BMC uses these commands to determine if FW needs updating:
 MFR_FW_REVISION
 MFR_MODEL
 MFR_FW_UPLOAD_MODE
 MFR_HW_COMPATIBILITY
 MFR_FW_UPLOAD_CAPABILITY

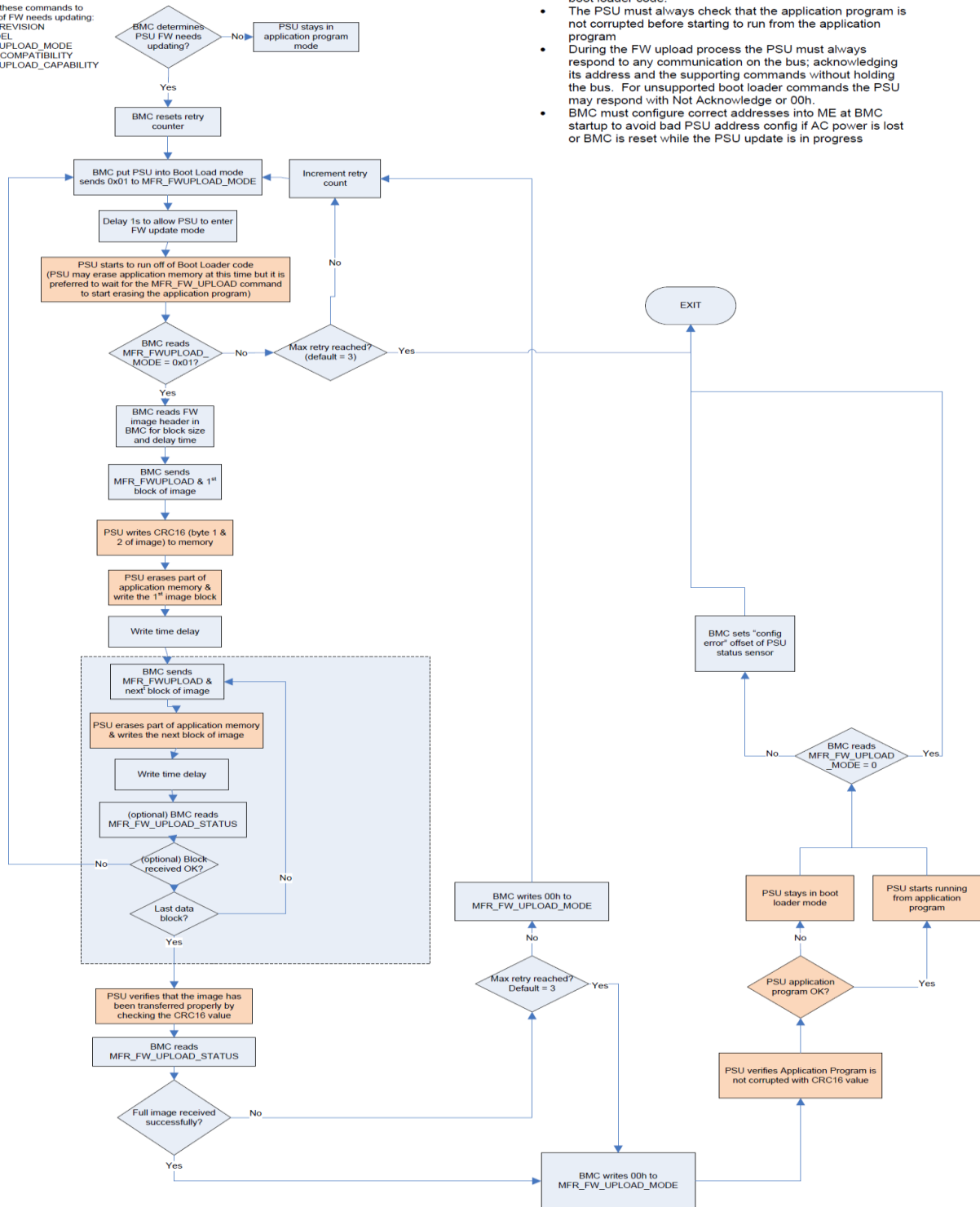

IMPORTANT!

- PSU may be in standby mode or ON mode during FW update process
- If the FW update process is interrupted at any point during the process; the PSU must always be able to return to the boot loader code.
- The PSU must always check that the application program is not corrupted before starting to run from the application program
- During the FW upload process the PSU must always respond to any communication on the bus; acknowledging its address and the supporting commands without holding the bus. For unsupported boot loader commands the PSU may respond with Not Acknowledge or 00h.
- BMC must configure correct addresses into ME at BMC startup to avoid bad PSU address config if AC power is lost or BMC is reset while the PSU update is in progress

PMBUS™ SPECIFICATIONS

PSU Flow During Powering ON

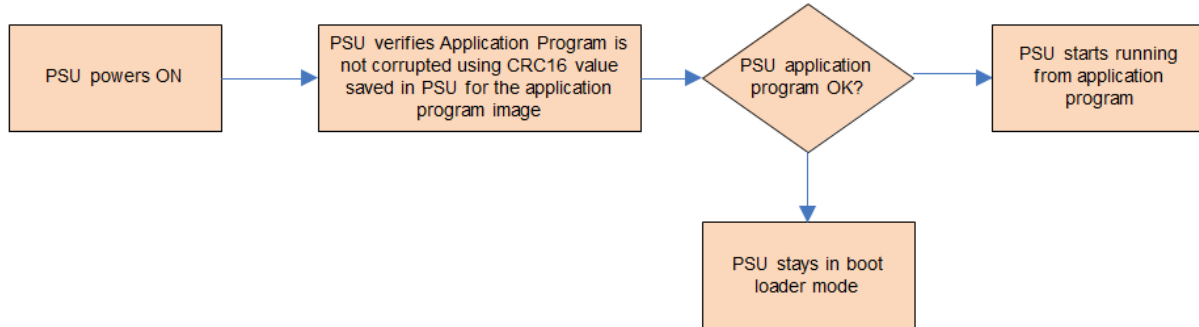

APPLICATION NOTES

Current Sharing

The CSU550AP series' main output V_O is equipped with current sharing capability. This allows up to 4 power supplies to be connected in parallel for higher power application. Current share accuracy is typically 5% of full load. When supplying light loads between 15% and 25% of its rated load, the power supplies will share within 10% accuracy. Below 15% total loading, there is no guarantee of output current sharing.

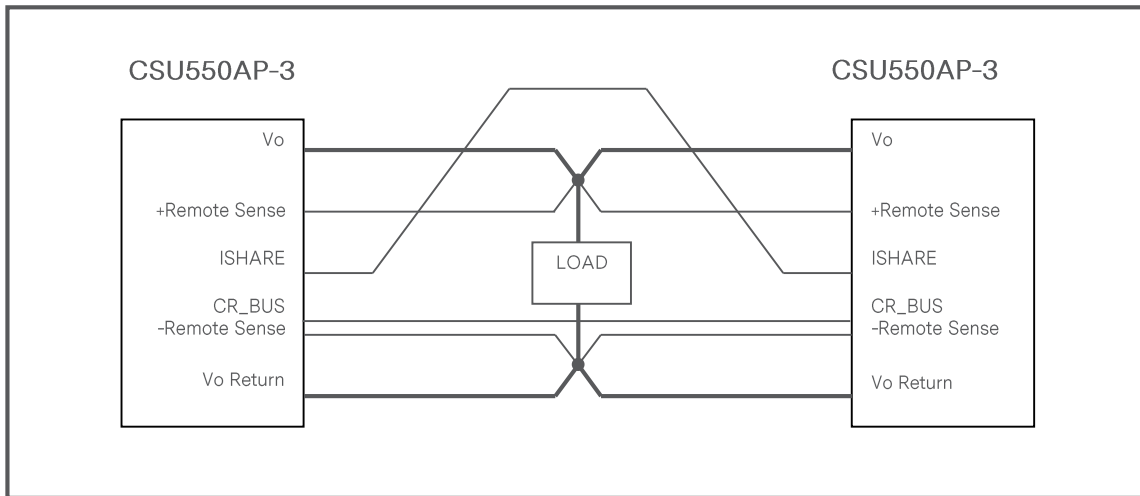

APPLICATION NOTES

Output Ripple and Noise Measurement

The setup outlined in the diagram below has been used for output voltage ripple and noise measurements on the CSU550AP series. When measuring output ripple and noise, a scope jack in parallel with a $0.1\mu\text{F}$ ceramic chip capacitor, and a $10\mu\text{F}$ tantalum capacitor will be used. Oscilloscope can be set to 20MHz bandwidth for this measurement.

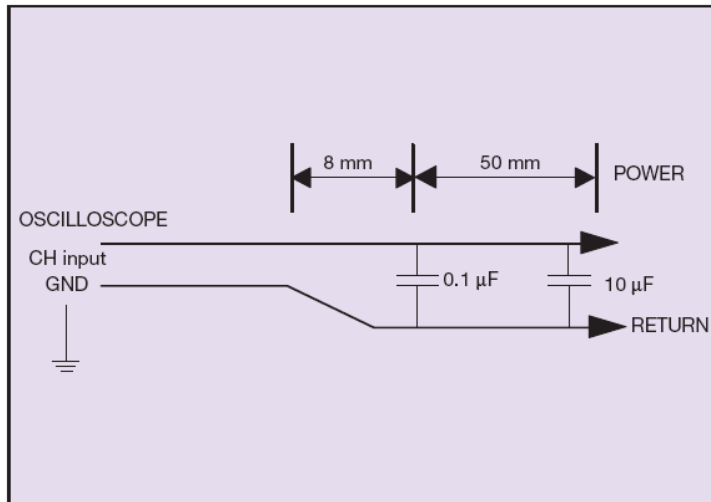

RECORD OF REVISION AND CHANGES

Issue	Date	Description	Originators
1.0	01.20.2017	First Issue	Alex.Li
1.1	09.02.2017	Updated the command list and the iTHD	Alex.Li
1.2	09.07.2017	Added the firmware updating process	Alex.Li
1.3	10.31.2017	Update the FRU data	A. Zhang
1.4	03.09.2018	1.Update “Always Standby” to “Always Cold Standby” 2.Update the PSON 3. Add a diagram to current share section	K. Wang
1.5	01.18.2019	Update the type error from 238 to 230 bytes	K. Wang
1.6	06.04.2019	Update the Command List	K. Wang
1.7	07.02.2019	Update “9Dh” description	K. Wang
1.8	10.16.2019	Update the black box to 230 byte	K. Wang
1.9	04.13.2019	Update 3A 1 - Fan is commanded in RPM 0 - Fan is commanded in Duty cycle	K. Wang
2.0	06.25.2021	Update the mechanical drawing	A. Zhang
2.1	09.07.2021	Update PWOK signal circuit for customer system side	C. Liu
2.2	06.02.2022	Update Some Format Issue and add UKCA Mark Update the EMC immunity, safety certificates and some typos	K. Wang A. Zhang
2.3	11.29.2022	Update the description for output return and chassis isolation	A. Zhang
2.4	05.15.2025	Update the Command List	A. Zhang
2.5	04.24.2025	Update Mechanical drawing	K. Wang



For international contact information,
visit advancedenergy.com.

powersales@aei.com (Sales Support)
productsupport.ep@aei.com (Technical Support)
+1 888 412 7832

ABOUT ADVANCED ENERGY

Advanced Energy (AE) has devoted more than three decades to perfecting power for its global customers. AE designs and manufactures highly engineered, precision power conversion, measurement and control solutions for mission-critical applications and processes.

Our products enable customer innovation in complex applications for a wide range of industries including semiconductor equipment, industrial, manufacturing, telecommunications, data center computing, and medical. With deep applications know-how and responsive service and support across the globe, we build collaborative partnerships to meet rapid technological developments, propel growth for our customers, and innovate the future of power.

PRECISION | POWER | PERFORMANCE

Specifications are subject to change without notice. Not responsible for errors or omissions. ©2020 Advanced Energy Industries, Inc. All rights reserved. Advanced Energy®, and AE® are U.S. trademarks of Advanced Energy Industries, Inc.